

# ***Pinnacle-KR II***

Loudspeaker systems

ASSEMBLY MANUAL

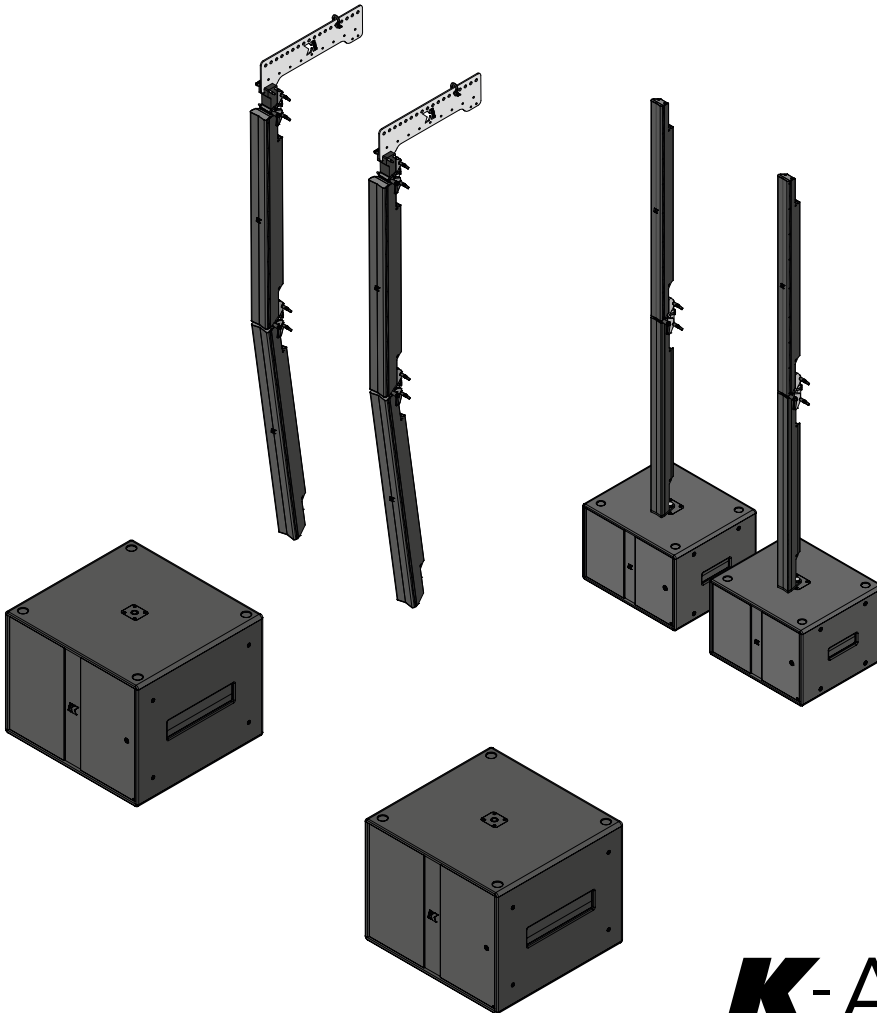

**K-ARRAY**  
Unique Audio Solutions

## IMPORTANT SAFETY INSTRUCTIONS



**CAUTION**

RISK OF ELECTRIC SHOCK  
DO NOT OPEN



**ATTENTION:** RISQUE DE CHOC ELECTRIQUE NE PAS OUVRIR

---

**CAUTION: TO REDUCE THE RISK OF ELECTRIC SHOCK,  
DO NOT REMOVE COVER (OR BACK).  
NO USER-SERVICEABLE PARTS INSIDE.  
REFER SERVICING TO QUALIFIED SERVICE PERSONNEL.**



This symbol alerts the user to the presence of recommendations about the product's use and maintenance.



The lighting flash with arrowhead symbol within an equilateral triangle is intended to alert the user to the presence of uninsulated, dangerous voltage within the product enclosure that may be of magnitude to constitute a risk of electrical shock.



The exclamation point within an equilateral triangle is intended to alert the user to the presence of important operating and maintenance (servicing) instructions in this guide.



Operator's manual; operating instructions  
This symbol identifies the operator's manual that relates to the operating instructions and indicates that the operating instructions should be considered when operating the device or control close to where the symbol is placed.



For indoor use only  
This electrical equipment is designed primarily for indoor use.



WEEE  
Please dispose of this product at the end of its operational lifetime by bringing it to your local collection point or recycling center for such equipment.



This device complies with Restriction of Hazardous Substances Directive.



Warning. Failure to follow these safety instructions could result in fire, shock or other injury or damage to the device or other property.

## General heed and warnings

- Read these instructions.
- Keep these instructions.
- Heed all warnings.
- Follow all instructions.
- Do not use this apparatus near water.
- Clean only with dry cloth.
- Do not block any ventilation openings. Install in accordance with the manufacturer's instructions.
- Do not install near any heat sources such as radiators, heat registers, stoves, or other apparatus (including amplifiers) that produce heat
- Do not defeat the safety purpose of the polarized or grounding plug. A polarized plug has two blades with one wider than the other. A grounding plug has two blades and a third grounding prong. The wide blade or the third prong is provided for your safety. If the provided plug does not fit into your outlet, consult an electrician for replacement of the obsolete outlet.
- Only use attachments/accessories specified by the manufacturer.
- Protect the power cord from being walked on or pinched particularly at the plugs, convenience receptacles, and at the point where they exit from the apparatus.
- Clean the product only with a soft and dry fabric. Never use liquid cleaning products, as this may damage the products cosmetic surfaces.
- Use only with the cart, stand, tripod, bracket, or table specified by the manufacturer, or sold with the apparatus. When a cart is used, use caution when moving the cart/apparatus combination to avoid injury from tip-over.
- Unplug this apparatus during lightning storms or when unused for long periods of time.
- Avoid placing the product in a location under direct sunlight or near any appliance that generates UV (Ultra Violet) light, as this may change the product surface finishing and cause a change in color.
- Refer all servicing to qualified service personnel. Servicing is required when the apparatus has been damaged in any way, such as power-supply cord or plug is damaged, liquid has been spilled or objects have fallen into the apparatus, the apparatus has been exposed to rain or moisture, does not operate normally, or has been dropped.
- **CAUTION:** These servicing instructions are for use by qualified service personnel only. To reduce the risk of electric shock, do not perform any servicing other than that contained in the operating instructions unless you are qualified to do so.
- **WARNING:** Only use attachments/accessories specified or provided by the manufacturer (such as the exclusive supply adapter, battery, etc.)



This apparatus is intended for professional use.

Installation and commissioning may only be carried out by qualified and authorized personnel.

- Before turning the power on or off for all devices, set all volume levels to minimum.
- Use only speaker cables for connecting speakers to the speaker terminals. Be sure to observe the amplifier's rated load impedance particularly when connecting speakers in parallel. Connecting an impedance load outside the amplifier's rated range can damage the apparatus.
- K-array cannot be held responsible for damage caused by improper use of the loudspeakers.
- K-array will not shoulder any responsibilities for products modified without prior authorization.

### FCC Statement

This equipment has been tested and found to comply with the limits for a Class B digital device, pursuant to part 15 of the FCC Rules. These limits are designed to provide reasonable protection against harmful interference in a residential installation. This equipment generates, uses and can radiate radio frequency energy and, if not installed and used in accordance with the instructions, may cause harmful interference to radio communications. However, there is no guarantee that interference will not occur in a particular installation. If this equipment does cause harmful interference to radio or television reception, which can be determined by turning the equipment off and on, the user is encouraged to try to correct the interference by one or more of the following measures:



1. Reorient or relocate the receiving antenna.
2. Increase the separation between the equipment and receiver.
3. Connect the equipment into an outlet on a circuit different from that to which the receiver is connected.
4. Consult the dealer or an experienced radio/TV technician for help.

### FCC Radiation Exposure Statement

This device complies with FCC radiation exposure limits set forth for an uncontrolled environment. This equipment must be installed and operated in accordance with provided instructions and the antenna(s) used for this transmitter must be installed to provide a separation distance of at least 20 cm from all persons.

This device complies with Part 15 of the FCC Rules. Operation is subject to the following two conditions:

1. this device may not cause harmful interference, and
2. this device must accept any interference received, including interference that may cause undesired operation.

**CAUTION!** Any changes or modifications not expressly approved by the party responsible for compliance could void the user's authority to operate the equipment.

### Canadian Statement

This device complies with Industry Canada's licence-exempt RSSs.

Operation is subject to the following two conditions: this device may not cause interference, and this device must accept any interference, including interference that may cause undesired operation of the device.

The device meets the exemption from the routine evaluation limits in section 2.5 of RSS-102 and compliance with RSS-102 RF exposure, users can obtain Canadian information on RF exposure and compliance. This equipment should be installed and operated with a minimum distance of 20 centimeters between the radiator and your body.

### CE Statement

K-array declares that this device is in compliance with applicable CE standards and regulations. Before putting the device into operation, please observe the respective country-specific regulations!



### Trademark Notice

All trademarks are the property of their respective owners.



## Index

General heed and warnings	II	Output configuration	15
FCC Statement	III	Signal Routing	15
FCC Radiation Exposure Statement	III	Volume	16
Canadian Statement	III	Media Player	16
CE Statement	III	On-Board Web App	17
Trademark Notice	III	System Update	17
<b>Unpacking</b>	2	System Update via Internet	18
Basic Bundle Systems	2	System Update via USB	18
Pinnacle-KR102 II	2	<b>K-framework3 Software</b>	19
Pinnacle-KR202 II	3	Discovery	19
Pinnacle-KR402 II	3	Grouping	19
Pinnacle-KR802 II	4	<b>DSP Block Diagram</b>	19
<b>Assembling instructions</b>	4	<b>Service</b>	20
Assembly: ground stack	8	<b>Cleaning</b>	20
Assembly: suspended	9	<b>Mechanical Drawings</b>	20
<b>AC mains supply</b>	10	Kobra-KK102 I	20
<b>Loudspeakers Wiring</b>	10	Python-KP102 I	20
Single Loudspeaker System	10	Kayman-KY102	20
Active + Passive Loudspeakers System	11	Thunder-KS1 I/KS1PI	21
<b>Connectivity</b>	12	Thunder-KS2I/KS2PI	21
K-array Connect	12	Thunder-KS3I/KS4PI	21
K-framework3	12	Thunder-KS4 I/KS4PI	21
Connectivity Reset	12	<b>Technical Specifications</b>	22
<b>K-array Connect Mobile App</b>	12		
Connection and Discovery	12		
Connection to a single Thunder-KS	12		
Connection to a network of Thunder-KS	14		

# ***Pinnacle-KR***

Assembly Manual

This page intentionally left blank

Thank you for choosing this K-array products!

To ensure proper operation, please carefully read the owner's manuals and safety instruction before using the products. After reading this manual, be sure to keep it for future reference.

Should you have any questions about your new device please contact K-array customer service at [support@k-array.com](mailto:support@k-array.com) or contact the official K-array distributor in your country.

---

Pinnacle-KR is a line of integrated, self-powered loudspeaker systems composed of Thunder-KS subwoofers and top line array loudspeaker elements from the Kobra, Python and Kayman series.

Taking advantage of the modularity of the systems and thanks to the available accessories for ground stacking or suspending the loudspeakers, the Pinnacle-KR systems can be assembled in many configurations suiting any application: from outdoor light parties to auditorium, from conference rooms to beach clubs and more.

Enhanced performance and easy tuning are now managed by the Integrated Electronic Brain – IEB – implemented into K-array amplifiers. More than a traditional DSP, the built-in micro electronics driven by the integrated operating system *osKar* features extensive sound processing, offering complete user control over the system performance: Volumes, Signal Routing, Presets as well as a complete USB player, are directly manageable from the device via mobile app and dedicated professional interface.

# Pinnacle-KR

## Assembly Manual

### Unpacking

Each K-array product is built to the highest standard and thoroughly inspected before leaving the factory. Upon arrival, carefully inspect the shipping carton, then examine and test your new device. If you find any damage, immediately notify the shipping company.

Each Pinnacle-KR configuration is a bundle composed of a set of elements optimized to reach the desired performance, according to the application. Extended performance can be achieved by adding more elements to the factory configurations as well as combining more bundles, making the Pinnacle-KR a scalable solution tailored to the contest.

Check that the following parts are supplied with the bundle.

	KR102 II	KR202 II	KR204 II	
Kobra-KK	2	4	8	
Thunder-KS1	1			
Thunder-KS1P	1			KR2
Thunder-KS2		1	2	
Thunder-KS2P		1	2	
	KR402 II	KR404 II		
Python-KP		4	8	
Thunder-KS3		1	2	KR3
Thunder-KS3P		1	2	
	KR802 II	KR804 II		
Kayman-KY		4	8	
Thunder-KS4		1	2	KR4
Thunder-KS4P		1	2	

### Basic Bundle Systems

The Pinnacle-KR102II, Pinnacle-KR202II, Pinnacle-KR402II and Pinnacle-KR802II are basics bundles: further bundles are available, e.g. Pinnacle-KR404II, based on these configurations.

#### Pinnacle-KR102 II

Bill of material	
2	Kobra-KK102 I Stainless steel meter-long line array element with 2" drivers
1	Thunder-KS1 I Lightweight, multi-tasking 12" self-powered subwoofer
1	Thunder-KS1P I Lightweight, 12" passive subwoofer
2	K-KKPOLE Fake Kobra 100 cm pole support
2	K-JOINT3 Joining hardware to connect Kobra loudspeakers
1	K-SPKCABLE15 4-pole speaker cable with SpeakON NL4, 15 m (49 ft)
2	K-SPKCABLE2 4-pole speaker cable with SpeakON NL4, 2 m (6.5 ft)
1	Power cable with PowerCON TRUE

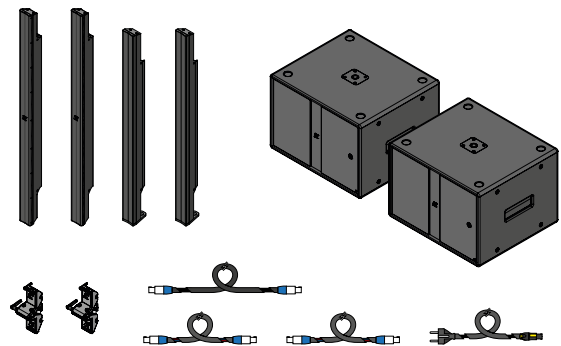



### Pinnacle-KR202 II

Bill of material	
4	Kobra-KK102 I Stainless steel meter-long line array element with 2" drivers
1	Thunder-KS2 I Lightweight, multi-tasking 18" self-powered subwoofer
1	Thunder-KS2P I Lightweight, 18" passive subwoofer
2	K-FOOT3 Adapter for standing loudspeakers on top of Thunder sub
4	K-JOINT3 Joining hardware to connect Kobra loudspeakers
1	K-SPKCABLE15 4-pole speaker cable with SpeakON NL4, 15 m (49 ft)
2	K-SPKCABLE2 4-pole speaker cable with SpeakON NL4, 2 m (6.5 ft)
2	K-SPKCABLE235 4-pole joint cable with SpeakON NL4, 22,5 cm (9 in)
1	Power cable with PowerCON TRUE

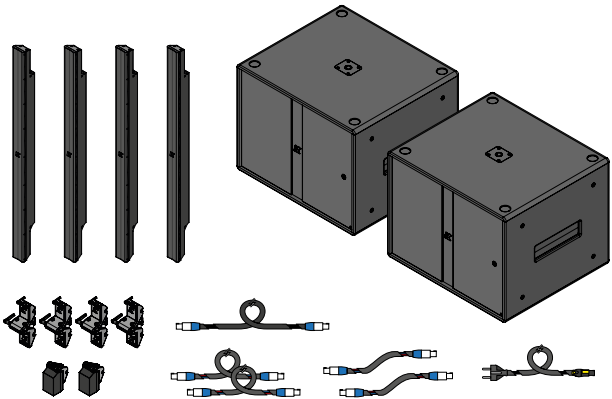

### Pinnacle-KR402 II

Bill of material	
4	Python-KP102 I Stainless steel meter-long line array element with 3" drivers
1	Thunder-KS3 I Compact, multi-tasking 21" self-powered subwoofer
1	Thunder-KS3P I Compact, 21" passive subwoofer
2	K-FOOT3 Adapter for standing loudspeakers on top of Thunder sub
4	K-JOINT3 Joining hardware to connect Python loudspeakers
1	K-SPKCABLE15 4-pole speaker cable with SpeakON NL4, 15 m (49 ft)
2	K-SPKCABLE2 4-pole speaker cable with SpeakON NL4, 2 m (6.5 ft)
2	K-SPKCABLE235 4-pole joint cable with SpeakON NL4, 22,5 cm (9 in)
1	Power cable with PowerCON TRUE

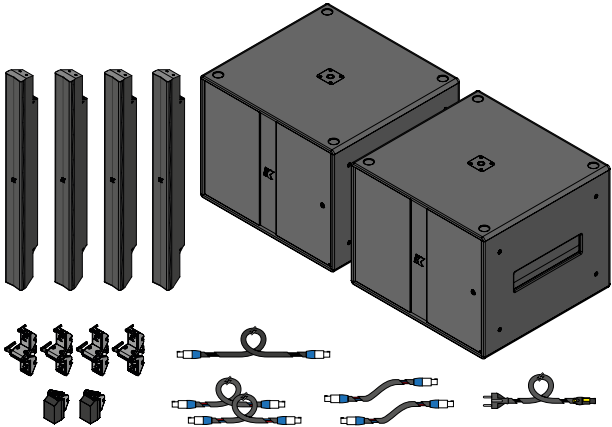

# Pinnacle-KR

## Assembly Manual

### Pinnacle-KR802 II

Bill of material	
4	Kayman-KY102 I Stainless steel meter-long line array element with 4" drivers
1	Thunder-KS4 I multi-tasking 2x18" self-powered subwoofer
1	Thunder-KS4P I 2x18" passive subwoofer
2	K-FOOT3 Adapter for standing loudspeakers on top of Thunder sub
4	K-JOINT3 Joining hardware to connect Python loudspeakers
1	K-SPKCABLE15 4-pole speaker cable with SpeakON NL4, 15 m (49 ft)
2	K-SPKCABLE2 4-pole speaker cable with SpeakON NL4, 2 m (6.5 ft)
2	K-SPKCABLE235 4-pole joint cable with SpeakON NL4, 22,5 cm (9 in)
1	Power cable with PowerCON TRUE

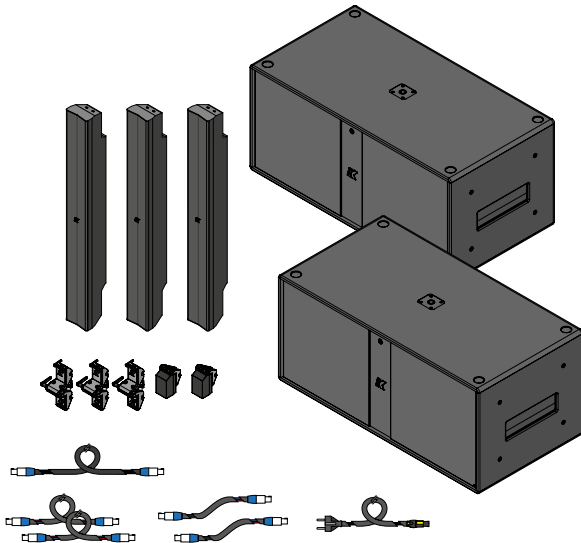

## Assembling instructions

The perfect sound reinforcement system tailors both the listening expectation and the aesthetics and architectural constraints.

The Pinnacle-KR systems are designed to give the sound engineer and integrators unparalleled scalability and elegant solutions matching any application with the dedicated custom loudspeaker configurations.

Few rules shall be followed in order to select the proper accessories and assembly a Pinnacle-KR bundle.

Joint	
K-JOINT3	Joining hardware to connect, fly or affix the loudspeakers

The new K-JOINT3 is a unique hardware purposed to connect, fly or affix the loudspeakers in line array configurations or to other hardware, such as the K-FLY3 fly bar or the K-FOOT3 ground stack joint.



Use one K-JOINT3 per loudspeaker.

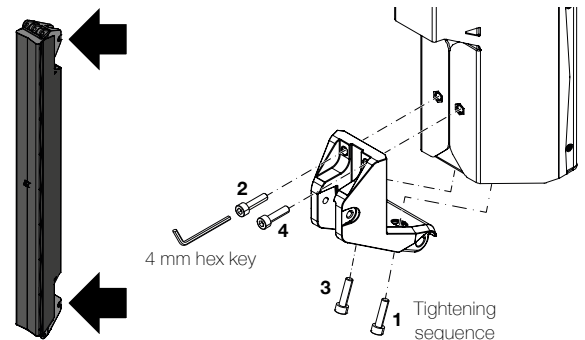

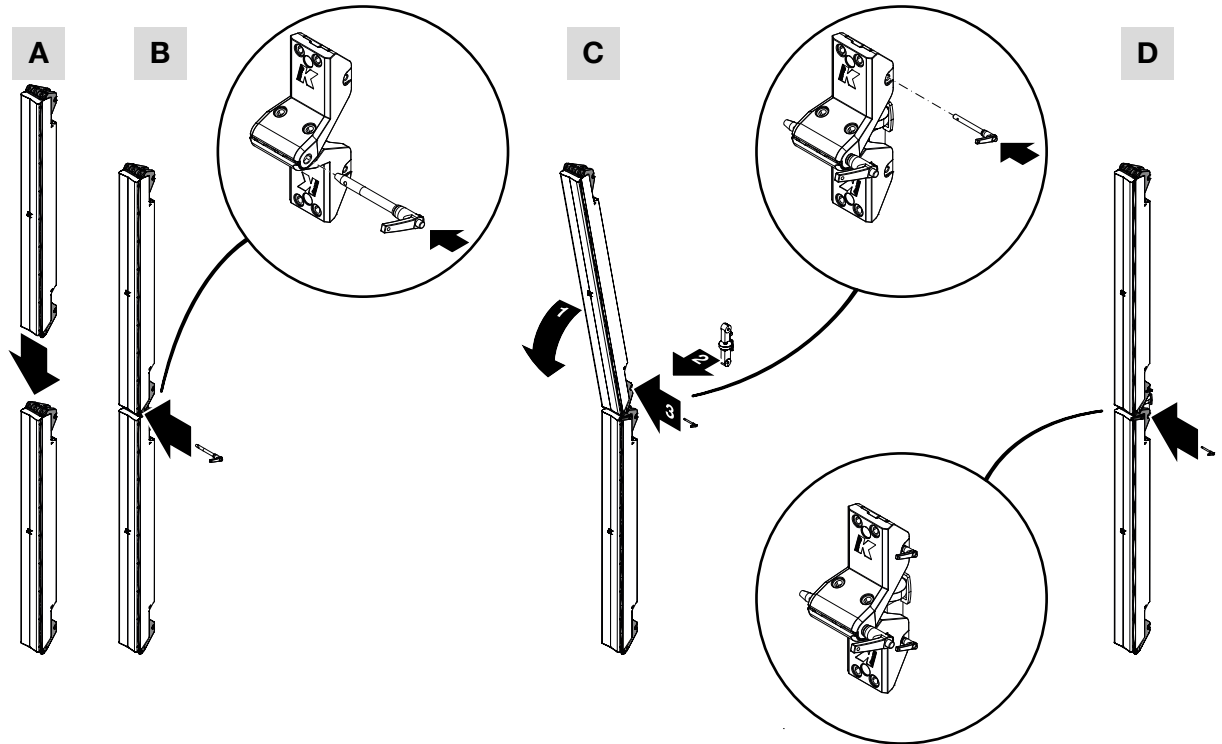

The K-JOINT3 provides fine adjustment of the tilting angle of the loudspeakers to control the system directivity.

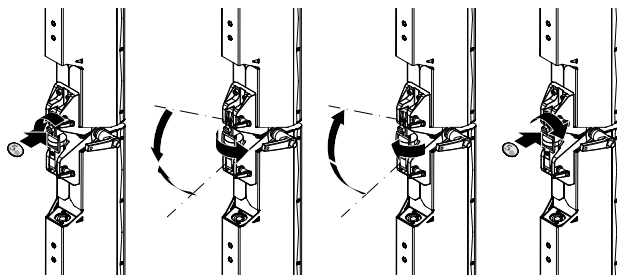

Loose the locking screw

Rotate the wheel in order to change the joint angle and tilt the loudspeakers

Tighten the locking screw

### Ground Stack

K-FOOT3

Adapter for standing loudspeakers on top of Thunder sub

How to assembly the K-JOINT3 hinge arm to the K-FOOT3.

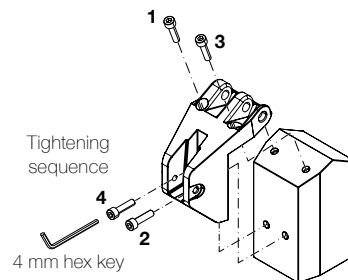

# Pinnacle-KR

## Assembly Manual

In order to set the K-FOOT3 on top of a Thunder-KS subwoofer, tightly screw the steel pivot to the M20 hole and then install the K-FOOT3.

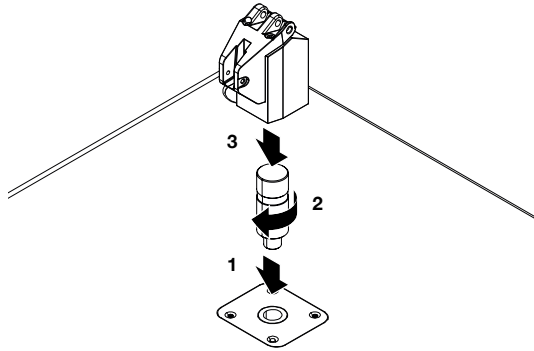

Follow the K-JOINT3 assembly instructions to join the loudspeaker to the K-FOOT3.

Suspended	
K-FLY3	Steel fly bar for suspending Kobra, Python, Kayman, KU26, KU44

How to assembly the K-JOINT3 hinge arm to the K-FLY3.

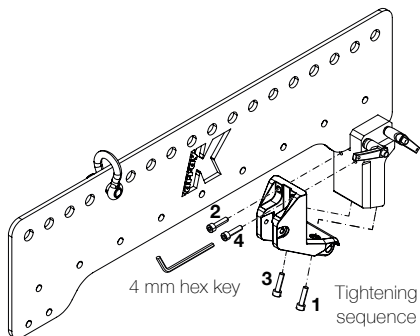

Follow the K-JOINT3 assembly instructions to join the loudspeaker to the K-FLY3.

### Wall mount (advanced bracket)

K-WALL2

Wall bracket with ball and socket joint (advanced model)

**A**

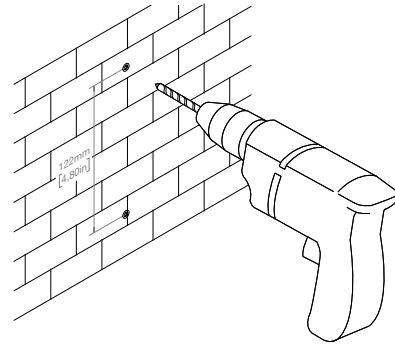

**B**

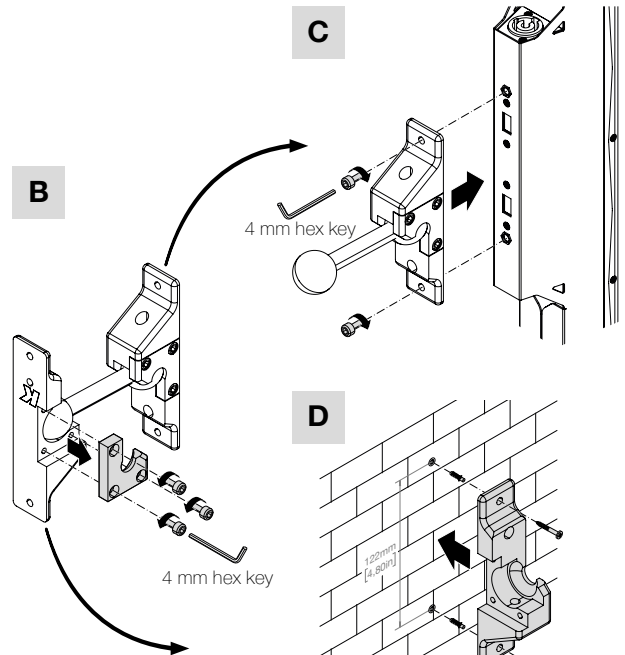

**C**

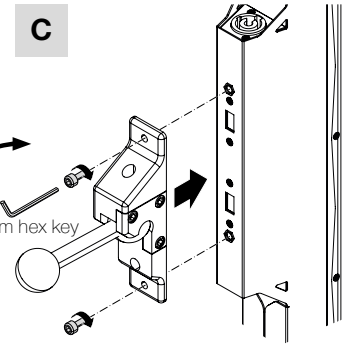

**D**

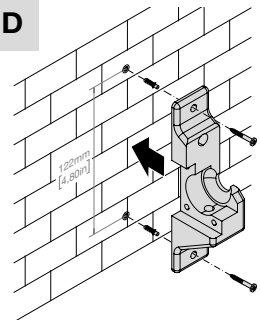

E

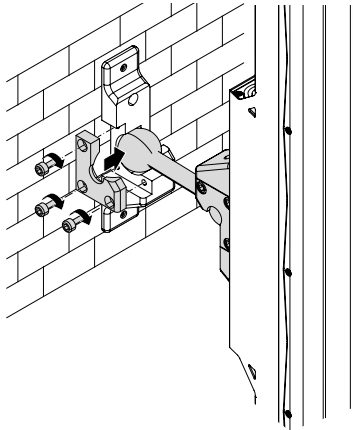

E

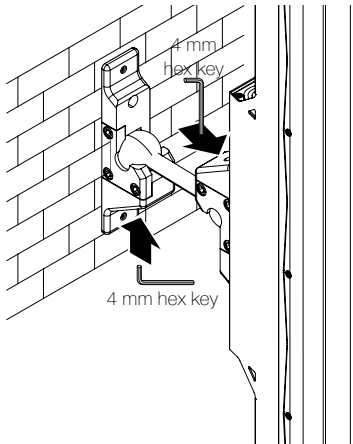

Aim the loudspeaker to the audience area and use the top and bottom hex socket set screws to tightly lock the bracket configuration.



In order to lock the loudspeaker position tighten the top and bottom hex socket set screws.

### Wall mount (basic bracket)

K-WALL2L

Lightweight bracket for wall mounting  
(basic model)

1

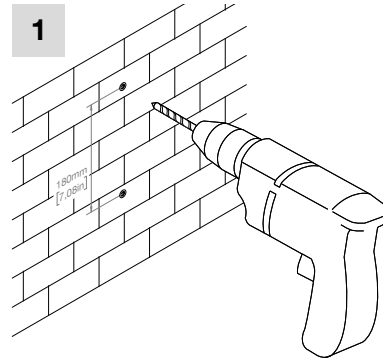

2

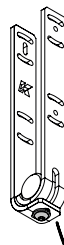

5 mm hex key

3

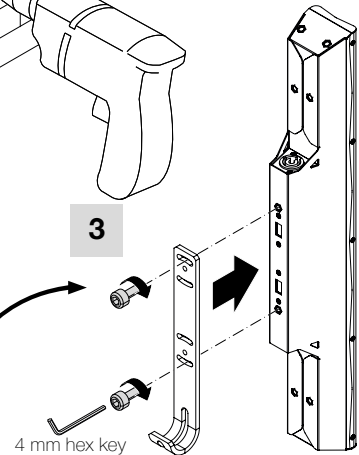

4

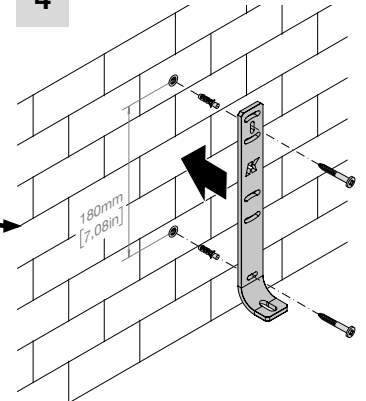

# Pinnacle-KR

## Assembly Manual

5

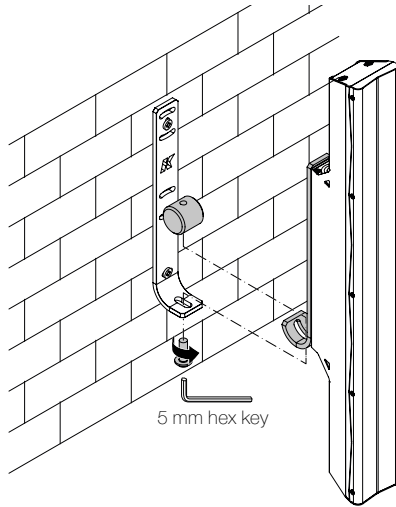

6

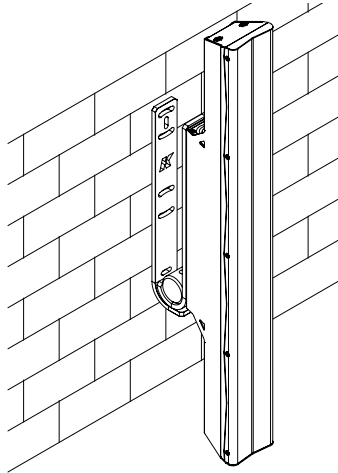

### Assembly: ground stack

1. Screw the K-JOINT3 hinge arms to the column loudspeaker(s) (see "Joint", page 4).
2. Set firmly the Thunder-KS subwoofer on a even horizontal surface.
3. Assemble the K-FOOT3 on top of the Thunder-KS subwoofer (see "Ground Stack", page 5). The Pinnacle-KR102 II system is provided with a pole shaped as a Kobra loudspeaker (K-KKPOLE) that can be screwed directly on top of the subwoofer.
4. Join the first loudspeaker to the K-FOOT3 – or to the K-KKPOLE according to the Pinnacle system model – (see "Joint", page 4).
5. If available, join the further loudspeakers to the one already assembled on top of the subwoofer.



The total height of the column loudspeakers shall not exceed 2 m (6.6 ft), i.e. no more than two meter-long units shall be stacked on top of the subwoofer.

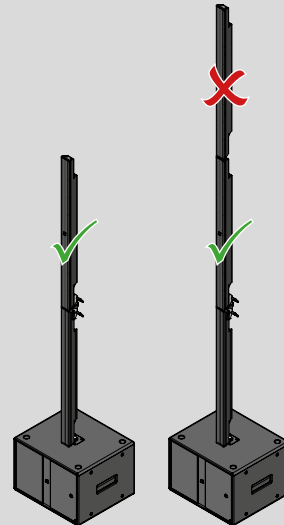

### Assembly: suspended

1. Use the K-framework3 simulator software in order to design the flown column loudspeaker configuration.
2. Screw the K-JOINT3 hinge arms to the column loudspeaker(s) (see "Joint", page 4).
3. Assemble the top column loudspeaker to the K-FLY3 (see "Suspended", page 6).
4. Hang the flybar at the rigging using the pin hole suggested by the K-framework3 simulator software.
5. Add and tilt the bottom loudspeaker(s) according to the configuration designed with the K-framework3 simulator software (see "Joint", page 4)
6. Set the Thunder-KS subwoofer(s) according to the configuration designed with the K-framework3 simulator software.



Design the flown column loudspeaker configuration with the latest version of the K-framework3 simulator software.

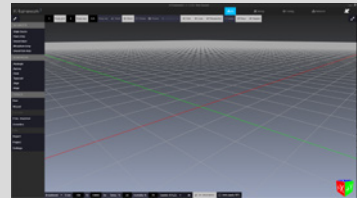

Launch the K-framework3 software and switch the interface to the 3D simulator.

1

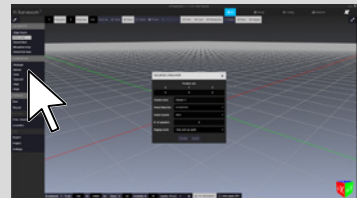

Add a flown array.

2

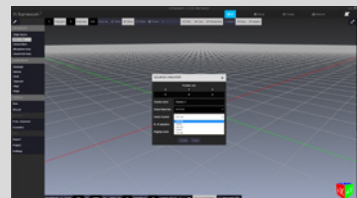

Select the desired column loudspeaker model (Kobra, Python or Kayman) and insert the number of units. The rigging mode is "One pick-up point".

4

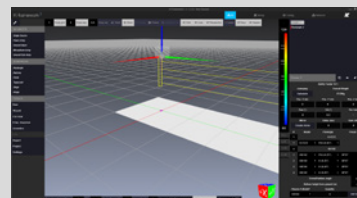

Add the listening area and shape it according to the location architecture.

5

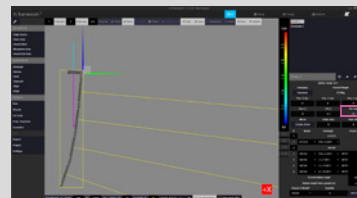

Aim the suspended loudspeaker at the listeners: modify the cluster tilting angle and the mechanical steering.

6

The K-framework3 will calculate the exact tilting angle and the proper pick-up point in the flybar.

# Pinnacle-KR

## Assembly Manual

### AC mains supply

The AC Main connection is made via the provided power cord: insert the powerCon TRUE flying connector into the Thunder-KS active subwoofer inlet and then rotate it clockwise.

Once properly plugged, the active subwoofer power up: the back LEDs light on.

The powerCon TRUE link (AC mains out) connector allows to distribute the AC main power to one further active unit.

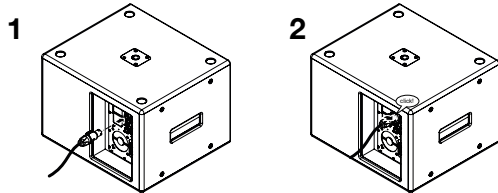

Please don't exceed the limit of two Thunder-KS active units linked and powered by the same line.

### Loudspeakers Wiring

The Thunder-KS active subwoofers features two NL4 speakOn output connectors designed to drive external Hi/Mid-range loudspeakers as well as other subwoofers or full-range passive loudspeakers systems.

A single loudspeaker system is composed of one Thunder-KS active subwoofer and one or more top loudspeakers. An active + passive loudspeakers system is composed of one Thunder-KS active subwoofer driving both one or more top loudspeakers and one passive Thunder-KS subwoofer with satellites (top loudspeakers).



The proper loudspeaker presets shall be loaded in the built in DSP using the dedicated K-array Connect app or the K-framework3 software BEFORE routing any audio signal to the output channels.

### Single Loudspeaker System

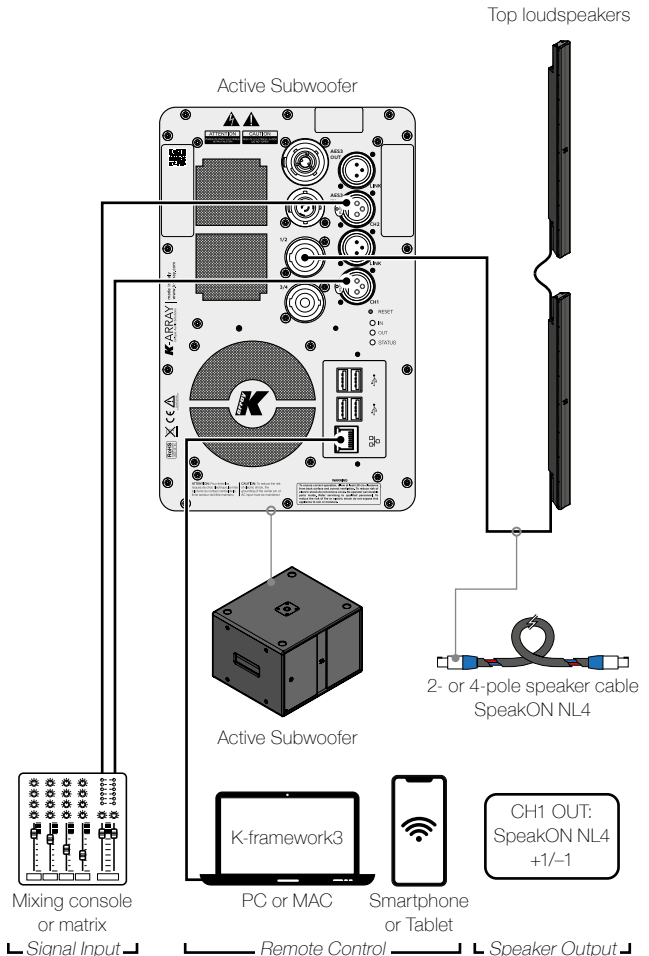



### Active + Passive Loudspeakers System

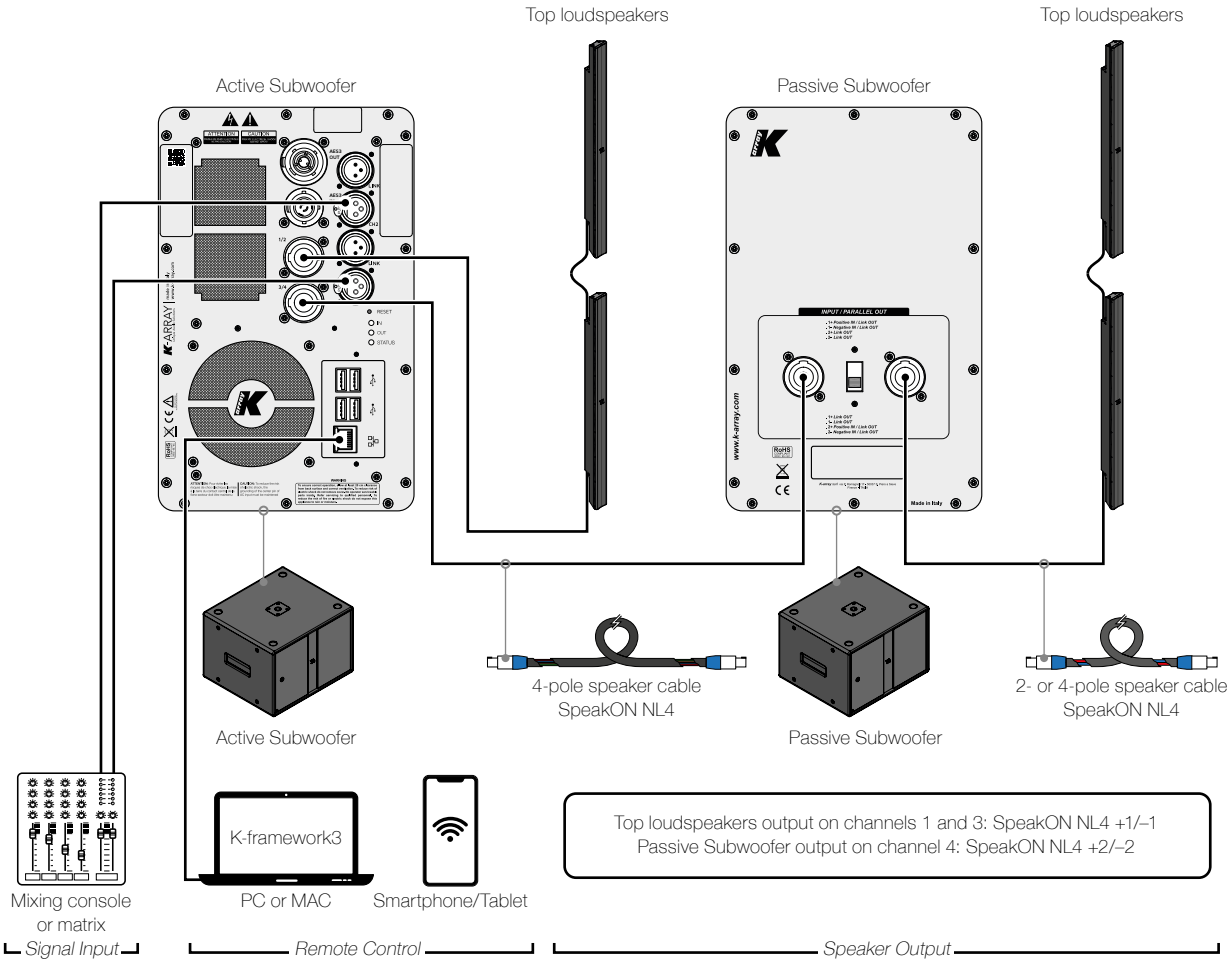

# Pinnacle-KR

## Assembly Manual

### Connectivity

The Pinnacle systems can be controlled remotely by a mobile device or desktop PC/MAC.

#### K-array Connect

K-array Connect is the mobile app that allows to direct manage and control one Kommander-KA amplifier at a time with wireless with a mobile device (smartphone or tablet).

Download the K-array Connect mobile APP from the dedicated store of your mobile device. Refer to "[K-array Connect Mobile App](#)", [page 12](#) for details about the system configuration.



#### K-framework3

The K-array K-framework3 is the managing and control software dedicated to professionals and operators looking for a powerful tool for designing and managing a large number of units in demanding applications (see "[K-framework3 Software](#)", [page 19](#) for details). Download the K-framework3 software from K-array website.



#### Connectivity Reset

Keep pressed the RESET button for 10 to 15 seconds in order to:

- Revert the wired IP addressing to DHCP;
- Activate the built-in Wi-Fi and reset the wireless parameters to the default SSID name and password (see "[K-array Connect Mobile App](#)", [page 12](#) for details).

### K-array Connect Mobile App

The K-array Connect mobile app is designed to allow any Android or iOS mobile device (smartphone or tablet) to connect and manage any Pinnacle-KR system via the Wi-Fi connection.

#### Connection and Discovery

The K-array Connect mobile app can connect to the Pinnacle-KR system both directly to the built-in Wi-Fi and wireless to an access point connected to a LAN where the Thunder-KS are wired to.

#### Connection to a single Thunder-KS

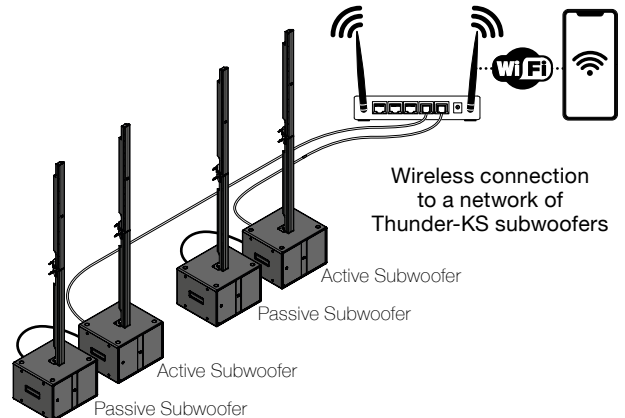
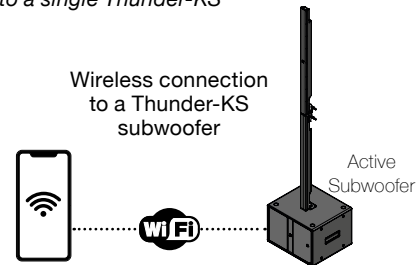

1. Ensure the Wi-Fi of the mobile device is on.
2. Launch the K-array Connect app.
  - a. In Android based systems the app looks for any Wi-Fi network whose SSID name starts with "K-array"; swipe down to force refresh the list of available networks.
  - b. Touch the device name to establish a connection and insert the password (see below).
3. If the list of available devices is empty touch the SCAN QR CODE button and use the mobile device camera to frame the QR code at the top left corner of the Thunder-KS rear panel: this provides the mobile device to connect to the Thunder-KS Wi-Fi network.
4. Enter the password to connect to Thunder-KS active subwoofer. If not modified, the default password is the device serial number, e.g. K142AN0006 (case sensitive).
5. The K-array Connect app connects directly to the Thunder-KS active subwoofer.

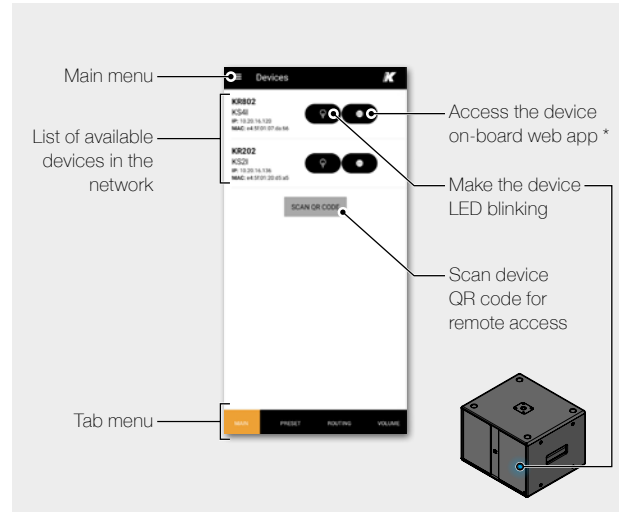

\* The on-board web interface is a further user interface embedded on the built-in DSP that allows to manage the system features over a network (see ["On-Board Web App"](#), page 17 for details). The K-array Connect mobile app offers a shortcut to access the on-board web interface.

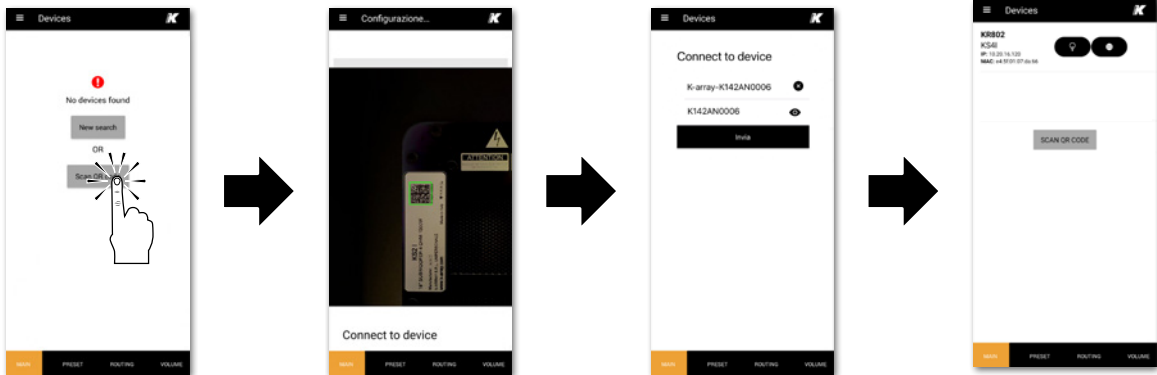

# Pinnacle-KR

## Assembly Manual

### Connection to a network of Thunder-KS

The Thunder-KS active subwoofers feature a RJ45 Ethernet port on the rear panel that allows to connect the loudspeakers to a local area network (LAN), in order to ease the remote control.

The Thunder-KS implements the zeroconf network technologies, allowing to direct connect the active subwoofer to a PC via the Ethernet CAT5 cables, as well as including the devices into a network without any user configuration.

The simplest local network of Thunder-KS active subwoofers requires the implementation of an Ethernet switch. When an access point is available, the network of Thunder-KS active subwoofers can be easily managed with the K-array Connect mobile app over the LAN.

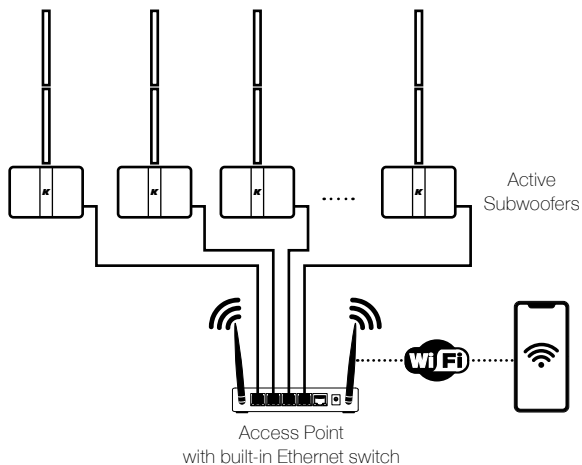

If a DHCP service is available, it will assign an IP address to each Thunder-KS. If a DHCP service is not available, each Thunder-KS active subwoofer will self assign an IP address in the range 169.254.0.0/16 (auto-IP).

1. Connect each Thunder-KS active subwoofer to a Wi-Fi access point with built-in Ethernet switch: use Ethernet Cat5 or Cat6 cables.
2. Set the access point Wi-Fi network SSID and parameters.
3. Ensure the Wi-Fi of the mobile device is on.
4. Connect the mobile device to the access point Wi-Fi network.
5. Launch the K-array Connect app: the app looks for any device in the network whose name starts with "K-array" and tries to establish a connection.
6. If the list of available devices is empty swipe down to force refresh the list of available devices.

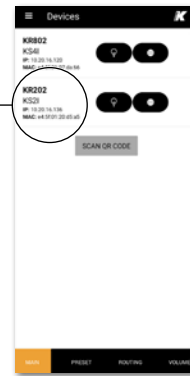

List of available devices in the network

**KR202** — Device Preset Name  
**KS21** — Subwoofer Model  
**IP: 10.20.16.136** — IP Address  
**MAC: e4:5f:01:20:d5:a5** — MAC address

### Output configuration

Once connected to the Thunder-KS active subwoofer (see "K-array Connect Mobile App", page 12 for details) the output configuration can be performed either using the on-board web interface or with the K-array Connect app, as described below.

- A. Touch the Preset tab in the tab menu at the bottom of the screen: this will modify the buttons in the list of available devices.
- B. Select the device you want to configure and touch the button to enter the Output Configuration page.

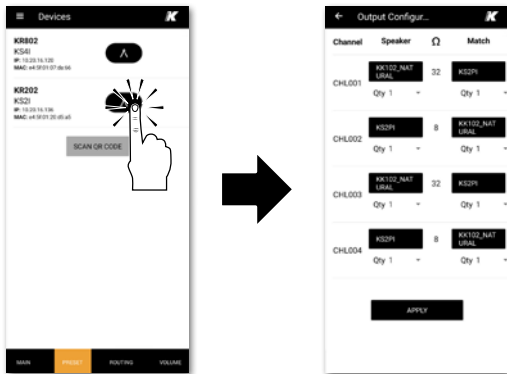

- C. In the Output Configuration page fill in the field according to the actual loudspeakers configuration: match the loudspeakers models and quantities connected to the Thunder-KS SpeakON output connectors.
- D. Once completed, save the output configuration touching the APPLY button at the bottom of the page.

### Signal Routing

The Thunder-KS active subwoofer features two analog inputs on channels 1 & 2, two digital inputs on channels 3 & 4 and four freely assignable audio power outputs. The internal transducer is wired in parallel to the output channel 2 (see Thunder-KS User Guide for details). Signal routing can be configured either with the on-board web app or with the K-array Connect app, as described below.

1. Touch the Routing tab in the tab menu at the bottom of the screen: this will modify the buttons in the list of available devices.

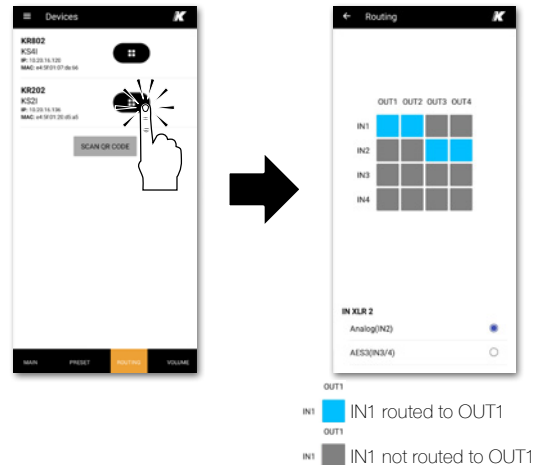

2. Select the device you want to configure and touch the button to enter the Routing table page.
3. Touch the squares in order to toggle the connection among the input channels on the left side to the output channels in the top side.
4. If needed, toggle the input channel 2 XLR connector analog or AES3.

# Pinnacle-KR

## Assembly Manual

### Volume

The Volume tab in the K-array-Connect mobile app provides access to volume adjustments for the input and output channels as well as the control of the signal gain at the analogue, digital and media player input.

1. Touch the Routing tab in the tab menu at the bottom of the screen: this will modify the buttons in the list of available devices.
2. Select the device you want to configure and touch the button to enter the volume adjustment section.



3. Three pages are available for setting the input gain, input level and output level respectively: touch the top menu buttons according to the needed adjustment.

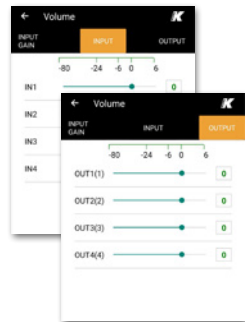

### Media Player

The Thunder-KS active subwoofer built-in DSP implements a media player that can be used to playback audio files from a USB device. The media player controls are accessible via the on-board web app user interface: see [“On-Board Web App”](#), page 17 for details.

The audio signals from the media players are routed by default to the input channels 3 & 4 as well as the AES3 input signals.

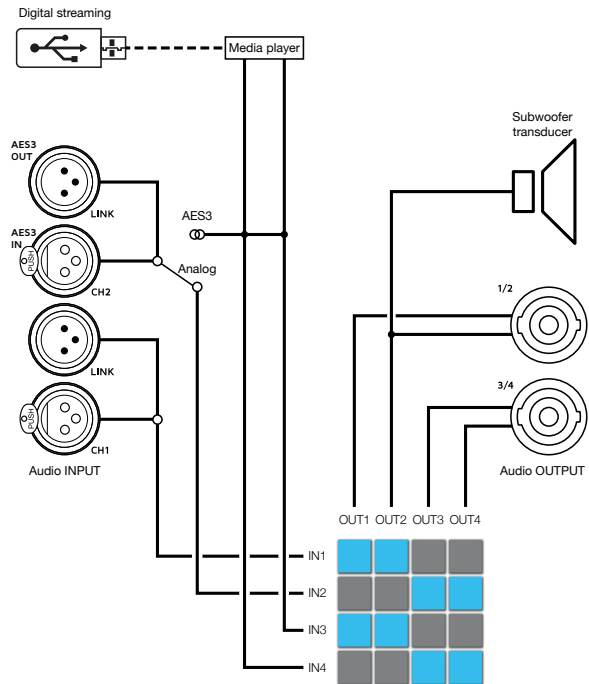

Default routing diagram.

### On-Board Web App

Once the IP address of a Thunder-KS active subwoofer is set and known, it is possible to access the built-in DSP features over a LAN with a web browser (Google Chrome is recommended):

- type the Thunder-KS active subwoofer IP address in the address field of the web browser (e.g. 10.20.16.171): the Thunder-KS will push the web interface for a direct access to its DSP features.

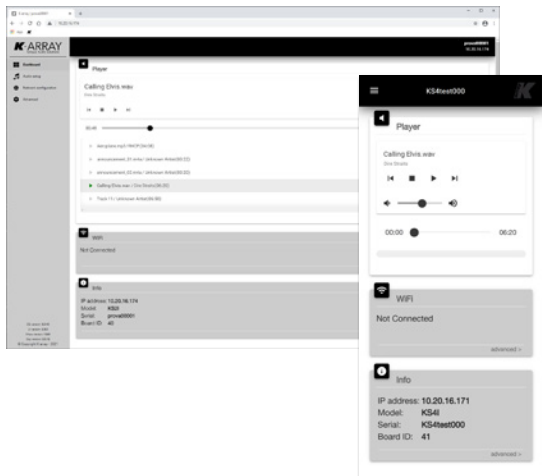

- The K-array Connect mobile app offers a shortcut to access the on-board web interface via any mobile device.

### System Update

The Thunder-KS active subwoofer built-in DSP is managed by an embedded operating system whose name is osKar. osKar manages the user interface and communication as well as the system features. osKar can be updated via the on-board web app.

- Access the Kommander-KA on-board web app either via the K-array Connect mobile app, or with a web browser within a LAN (see [“On-Board Web App”](#), page 17).



- Navigate the main menu and access the Advanced menu. The System Update section lists the current system version and, if the Kommander-KA amplifier is connected to a LAN with Internet access, the Available Version field is filled with the latest published system version number available on K-array website.

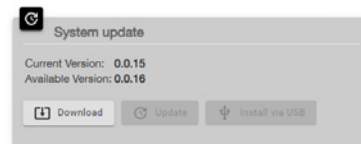

# Pinnacle-KR

## Assembly Manual

### System Update via Internet

When an Internet connection is available, the Kommander-KA amplifier's osKar embedded system can be updated directly from the on board web app.

1. Connect the Kommander-KA amplifier to a LAN with Internet access.
2. Access the Kommander-KA on board web app and open the Advanced menu page: the Download button becomes active if a higher system version is available on K-array website.
3. Click on the Download button in order to start downloading the system update file from the Internet: the file is saved inside the amplifier local memory.

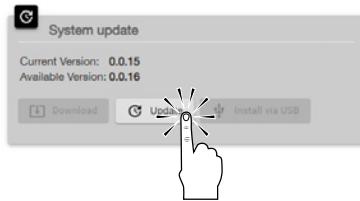

4. Once the download is finished, the Update button becomes active: click on the Update button to start updating the system.

The update procedure via Internet lasts in few minutes: at the end of the updating process the system reboots.

### System Update via USB

In order to update the Kommander-KA amplifier's osKar embedded operating system locally, a USB key with the system update files must be prepared in advance.

- A. Retrieve the system update file from the official K-array repository and move it into a folder named **update** on the USB key.

The system update file name ends with three numbers, e.g. 0.1.18, — namely the system version — and has **.mender** extension.

The update folder must contain only one system update file.

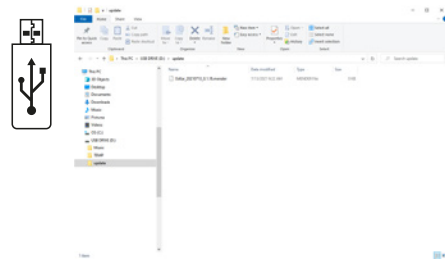

- B. Access the Kommander-KA on board web app and open the Advanced menu page: the Install via USB button becomes active if a valid update folder and .mender file are available on the USB key.
- C. Click on the Install via USB button in order to start the system update.

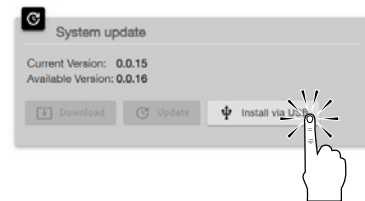

The update procedure via USB lasts in few minutes: at the end of the updating process the system reboots.



### K-framework3 Software

Use the K-array K-framework3 to control, configure and fine tune the Pinnacle-KR systems via a wired Ethernet network.

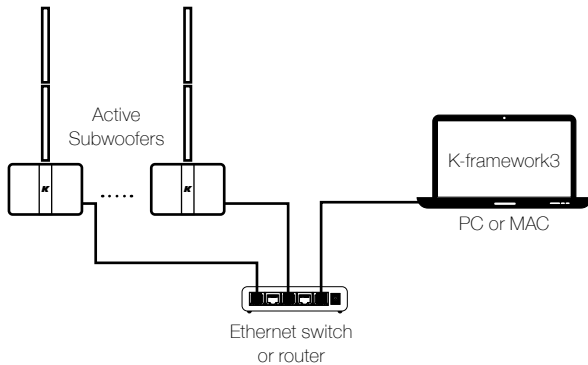

Every configuration made with the K-array Control mobile app or the built-in web app will be overridden by the K-framework3.

### Discovery

1. Ensure that every Pinnacle-KR system and the PC or Mac running the K-framework3 are properly connected to the same network.
2. Power up the active subwoofer(s).
3. Launch the K-framework3 and open the Network window.
4. Click on the Discovery button: the K-framework3 starts scanning the network looking for K-array devices.
  - a. If the K-framework3 finds two or more devices with conflicting ID, a dialog window appears where unique IDs can be assigned to each device.
5. Once discovered, click on the SYNC button in order to synchronize the devices and import them into the workspace.

### Grouping

The working paradigm is to group the devices' input and output channels and adjust the system performance within the groups.

- A. In Setup mode, set the amplifier local parameters (presets, routing, input gains, limiters, etc).

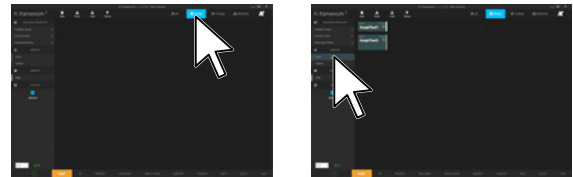

- B. Add INPUT and OUTPUT groups as needed.
- C. Assign the amplifier's channels to the groups.

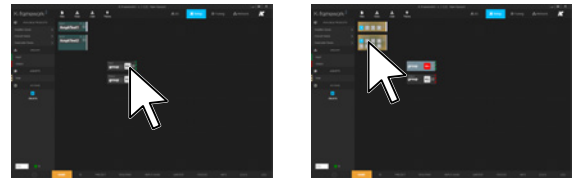

- D. In Tuning mode align the system (eq, delay, polarity, etc).

### DSP Block Diagram

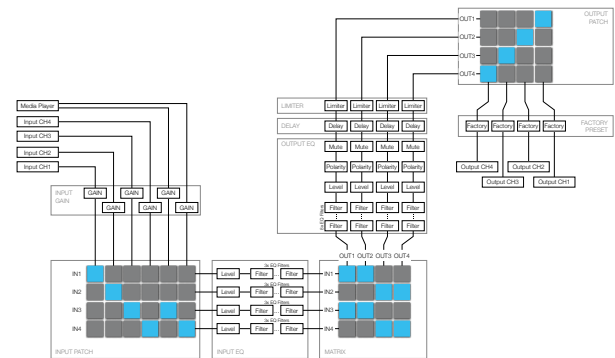

# Pinnacle-KR

## Assembly Manual

### Service

To obtain service:

1. Please have the serial number(s) of the unit(s) available for reference.
2. Contact the official K-array distributor in your country: find the Distributors and Dealers list on [K-array website](#). Please describe the problem clearly and completely to the Customer Service.
3. You will be contacted back for on-line servicing.
4. If the problem cannot be resolved over the phone, you may be required to send the unit in for service. In this instance, you will be provided with an RA (Return Authorization) number which should be included on all shipping documents and correspondence regarding the repair. Shipping charges are the responsibility of the purchaser.

Any attempt to modify or replace components of the device will invalidate your warranty. Service must be performed by an authorized K-array service center.

### Cleaning

Use only a soft, dry cloth to clean the housing. Do not use any solvents, chemicals, or cleaning solutions containing alcohol, ammonia, or abrasives. Do not use any sprays near the product or allow liquids to spill into any openings.

### Mechanical Drawings

Kobra-KK102 I

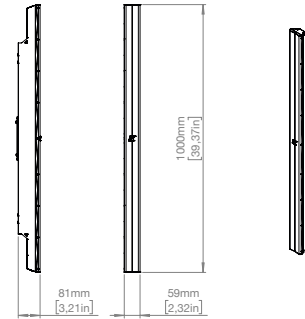

Python-KP102 I

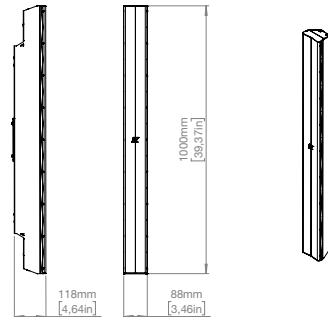

Kayman-KY102

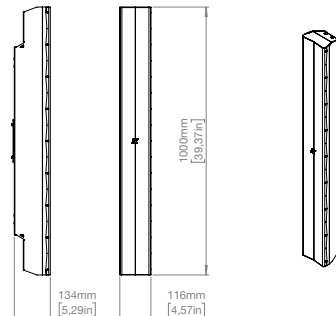

### Thunder-KS11/KS1PI

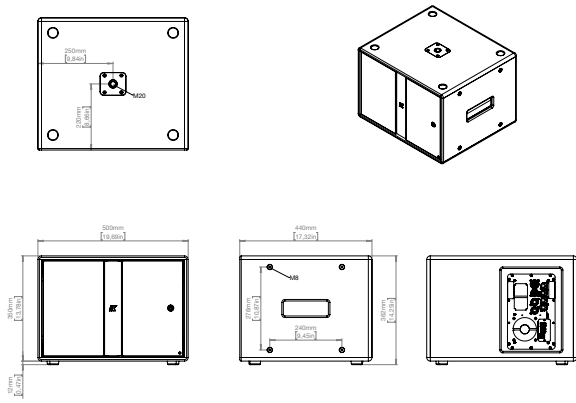

### Thunder-KS31/KS4PI

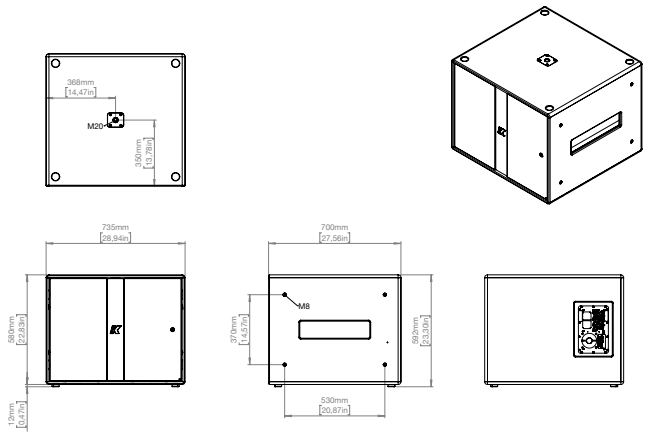

### Thunder-KS21/KS2PI

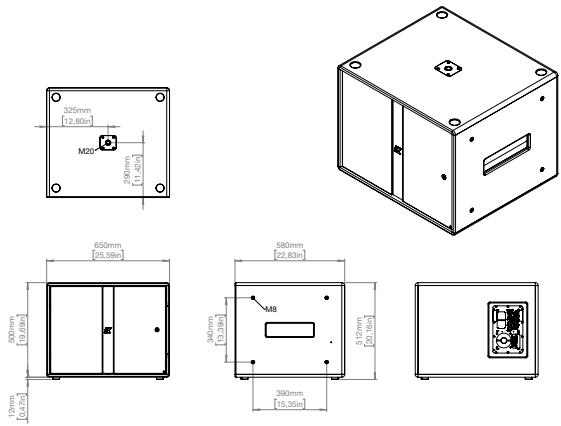

### Thunder-KS41/KS4PI

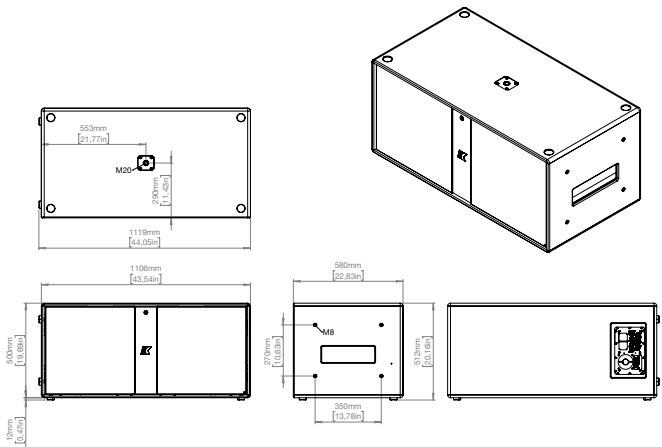

# Pinnacle-KR

## Assembly Manual

### Technical Specifications

	Kobra-KK102 I	Python-KP102 I	Kayman-KY102
Type	Passive line array loudspeaker		
Transducers	16 x 2" neodymium magnet woofers	12 x 3.15" neodymium magnet woofers	8 x 4" neodymium magnet woofers
Frequency Response <sup>1</sup>	150 Hz – 18 kHz (-6 dB)	120 Hz – 18 kHz (-6 dB)	150 Hz – 20 kHz (-6 dB)
Crossover	DSP-controlled, High Pass @ 150 Hz	DSP-controlled, High Pass @ 120 Hz	
Max SPL <sup>2</sup>	126 dB peak	134 dB peak	138 dB peak
Coverage	V. 7° - 35°   H. 120°	V. 7° - 30°   H. 90°	V. 7° - 30°   H. 90°
Nominal Impedance	8 Ω / 32 Ω selectable	4 Ω / 16 Ω selectable	8 Ω / 32 Ω selectable
Rated power	400 W	720 W	1200 W
Connectors	2x SpeakON NL4: 1+/1- transucers/link. 2+/2- through		
IP Rating <sup>3</sup>	IP64		
Dimensions (WxHxD)	59 x 1000 x 81 mm (2.3 x 39.4 x 3.2 in)	89 x 1000 x 118 mm (3.5 x 39.4 x 4.7 in)	116 x 1000 x 134 mm (4.6 x 39.4 x 5.3 in)
Weight	2.3 kg (5.07 lb)	5.8 kg (12.78 lb)	14.9 kg (32.8 lb)

<sup>1</sup> With dedicated K-array preset.

<sup>2</sup> Maximum SPL is calculated using a signal with crest factor 4 (12dB) measured at 8 m then scaled at 1 m.

<sup>3</sup> More complete water protection with K-IP65KITA and K-IP65KITB accessories (IP65 compliant).

Passive loudspeakers requires dedicated preset loaded on board of K-array amplifiers.

New materials and design are introduced into existing products without previous notice.

	Thunder-KS1I	Thunder-KS2I	Thunder-KS3I	Thunder-KS4I
Type	Active subwoofer			
Transducers	12" neodymium magnet woofer	18" neodymium magnet woofer	21" neodymium magnet woofer	2x 18" neodymium magnet woofer
Frequency Response <sup>1</sup>	35 Hz – 150/450 Hz (-6 dB) crossover dependent	35 Hz – 150/450 Hz (-6 dB) crossover dependent	30 Hz – 150/450 Hz (-6 dB) crossover dependent	35 Hz – 150/450 Hz (-6 dB) crossover dependent
Crossover	DSP-controlled, Low Pass @ 150 Hz up to 450 Hz, preset dependent			
Max SPL <sup>2</sup>	134 dB peak	137 dB peak	139 dB peak	141 dB peak
Coverage	Omni			
Connectors	Line Input 2x XLR-F analog balanced / AES3 input  Mains powerCON TRUE1 TOP, 16 A true mains  Networking and Data 1x RJ45 4x USB-A		Line Output 2x XLR-M Link analog balanced / AES3 output  Speaker Output 2x SpeakON NL4 (Ch1 1+/- // Ch2 2+/-)	
DSP	Input gain, routing matrix, delay, full parametric IIR filters (Peaking, Shelving, Hi/Lo pass, Hi/Lo Butterworth), On-board preset, Remote monitoring			
Remote control	Wi-Fi dedicated APP   K-framework3 via wired Ethernet connection			
Amplifier module	4-channel switching mode, Class D			
Output power <sup>3</sup>	4x 1500 W @ 4 Ω	4x 1500 W @ 4 Ω	4x 2500 W @ 4 Ω	4x 2500 W @ 4 Ω
MAINS Operating Range	100-240V AC, 50-60 Hz with PFC			
Power Consumption	600 W @ 8 Ω load, Pink noise, 1/4 rated power	600 W @ 8 Ω load, Pink noise, 1/4 rated power	600 W @ 4 Ω load, Pink noise, 1/4 rated power	600 W @ 4 Ω load, Pink noise, 1/4 rated power
Protections	Over Temp. (Power Limiting – Thermal Shutdown), Short Circuit/Overload Output Protection, Power Limiting, Clip Limiter/Permanent Signal Limiter, High Frequency Protection			
IP Rating	IP53			
Dimensions (WxHxD)	500 x 350 x 440 mm (19.7 x 13.8 x 17.3 in)	650 x 500 x 580 mm (25.6 x 19.7 x 22.8 in)	735 x 580 x 700 mm (28.9 x 22.83 x 20.87 in)	1106 x 500 x 580 mm (43.5 x 19.7 x 22.8 in)
Weight	21,6 kg (47.62 lb)	37,6 kg (82.9 lb)	56 kg (123.4 lb)	60 kg (132.3 lb)

<sup>1</sup> Extensible with dedicated preset according to the midrange crossover point.

<sup>2</sup> Maximum SPL is calculated using a signal with crest factor 4 (12dB) measured at 1 m.

<sup>3</sup> CTA-2006 (CEA-2006) Amplifier Power Standards, single channel driven.

# Pinnacle-KR

## Assembly Manual

	Thunder-KS1PI	Thunder-KS2PI	Thunder-KS3PI	Thunder-KS4PI
Type	Active subwoofer			
Transducers	12" neodymium magnet woofer	18" neodymium magnet woofer	21" neodymium magnet woofer	2x 18" neodymium magnet woofer
Frequency Response <sup>1</sup>	35 Hz – 150/450 Hz (-6 dB) crossover dependent	35 Hz – 150/450 Hz (-6 dB) crossover dependent	30 Hz – 150/450 Hz (-6 dB) crossover dependent	35 Hz – 150/450 Hz (-6 dB) crossover dependent
Crossover	External DSP-controlled, Low Pass @ 150 Hz up to 450 Hz, preset dependent			
Max SPL <sup>2</sup>	134 dB peak	137 dB peak	139 dB peak	141 dB peak
Nominal Impedance	8 Ω	8 Ω	4 Ω	4 Ω
Power Handling	1200 W <sub>peak</sub>	1400 W <sub>peak</sub>	2800 W <sub>peak</sub>	2800 W <sub>peak</sub>
Coverage	Omni			
Connectors	Speaker input/parallel output 2x SpeakON NL4		Input terminals selectable: IN+Link 1+/1- (parallel), Link 2+/2- Link 1+/1- , IN+Link 2+/2- (DEFAULT)	
IP Rating	IP54			
Dimensions (WxHxD)	500 x 350 x 440 mm (19.7 x 13.8 x 17.3 in)	650 x 500 x 580 mm (25.6 x 19.7 x 22.8 in)	735 x 580 x 700 mm (28.9 x 22.83 x 20.87 in)	1106 x 500 x 580 mm (43.5 x 19.7 x 22.8 in)
Weight	18 kg (39.7 lb)	34 kg (75 lb)	49,2 kg (108.5 lb)	53,2 kg (117.3 lb)

<sup>1</sup> Extensible with dedicated preset according to the midrange crossover point.

<sup>2</sup> Maximum SPL is calculated using a signal with crest factor 4 (12dB) measured at 1 m.

Passive loudspeakers requires dedicated preset loaded on board of K-array amplifiers.

New materials and design are introduced into existing products without previous notice.





**Designed and Made in Italy**

K-ARRAY surl  
Via P. Romagnoli 17 | 50038 Scarperia e San Piero - Firenze - Italy  
ph +39 055 84 87 222 | info@k-array.com

**[www.k-array.com](http://www.k-array.com)**