



# Astra Wash19Pix

19x40W RGBW moving wash light with  
4°-54° zoom, pixel control and pixel ring



---

## USER MANUAL

---

## ***Thank you for choosing PROLIGHTS***

Please note that every PROLIGHTS product has been designed in Italy to meet quality and performance requirements for professionals and designed and manufactured for the use and application as shown in this document.

Any other use, if not expressly indicated, could compromise the good condition/operation of the product and/or be a source of danger.

This product is meant for professional use. Therefore, commercial use of this equipment is subject to the respectively applicable national accident prevention rules and regulations.

Features, specifications and appearance are subject to change without notice. Music & Lights S.r.l. and all affiliated companies disclaim liability for any injury, damage, direct or indirect loss, consequential or economic loss or any other loss occasioned by the use of, inability to use or reliance on the information contained in this document.

Product user manual can be downloaded from the website [www.prolights.it](http://www.prolights.it), or can be inquired to the official PROLIGHTS distributors of your territory ([https://www.prolights.it/sales\\_network.html](https://www.prolights.it/sales_network.html)).

Scanning the below **QR Code**, you will access the download area of the product page, where you can find a broad set of always updated technical documentation: specifications, user manual, technical drawings, photometrics, personalities, fixture firmware updates.



Visit the download area  
of the product page



The PROLIGHTS Logo, PROLIGHTS names and all other trademark in this document pertaining to PROLIGHTS services or PROLIGHTS product are trademarks OWNED or licensed by Music & Lights S.r.l., its affiliates, and subsidiaries. PROLIGHTS is a registered trademark by Music & Lights S.r.l. All right reserved. Music & Lights – Via A. Olivetti, snc - 04026 - Minturno (LT) ITALY.

# INDEX

<b>SAFETY INFORMATION</b>	<b>02</b>
<b>1 - PACKAGING</b>	<b>05</b>
PACKAGE CONTENT .....	05
OPTIONAL ACCESSORIES .....	05
<b>2 - TECHNICAL DRAWING</b>	<b>05</b>
<b>3 - PAN AND TILT LOCK</b>	<b>06</b>
<b>4 - INSTALLATION</b>	<b>07</b>
MOUNTING .....	07
<b>5 - CONNECTION TO THE MAINS SUPPLY</b>	<b>08</b>
<b>6 - START UP</b>	<b>08</b>
CONNECT AND DISCONNECT POWER FROM THE PRODUCT .....	08
<b>7 - PRODUCT OVERVIEW</b>	<b>09</b>
<b>8 - DMX CONNECTION</b>	<b>10</b>
CONNECTION OF THE CONTROL SIGNAL: DMX LINE .....	10
INSTRUCTIONS FOR A RELIABLE DMX CONNECTION .....	10
CONNECTION DAISY CHAIN .....	10
CONNECTION OF THE DMX LINE .....	10
CONSTRUCTION OF THE DMX TERMINATION .....	11
DMX ADDRESSING .....	11
ETHERNET CONNECTION .....	11
ETHERNET OPERATION .....	11
ETHERNET TO DMX OPERATIONS .....	12
OPERATION AS A WIRELESS TRANSMITTER .....	12
IN TO WDMX .....	12
OPERATION AS A WIRELESS RECEIVER .....	13
WDMX TO DMX (RX) .....	13
<b>9 - CONTROL PANEL</b>	<b>14</b>
DISPLAY AND BUTTONS LAYOUT .....	14
<b>10 - MENU STRUCTURE</b>	<b>15</b>
<b>11 - SHORTCUT</b>	<b>19</b>
<b>12 - RDM FUNCTIONS</b>	<b>20</b>
<b>13 - DMX CHARTS</b>	<b>22</b>
Fixture Engine .....	22
Pixel Engine .....	23
<b>14 - RING LAYOUT</b>	<b>30</b>
<b>15 - PIXEL LAYOUT</b>	<b>30</b>
<b>16 - ERROR MESSAGES</b>	<b>31</b>
<b>17 - ACCESSORIES INSTALLATION</b>	<b>33</b>
EGG CRATE (ASTRAW19PEC - OPTIONAL) .....	33
<b>18 - PERIODICAL CLEANING</b>	<b>34</b>
<b>19 - MAINTENANCE</b>	<b>35</b>
MAINTENANCE AND CLEANING THE PRODUCT .....	35
REPLACING THE FUSE .....	35
VISUAL CHECK OF PRODUCT HOUSING .....	35
TROUBLESHOOTING .....	36

# SAFETY INFORMATION



## WARNING!

- Please read carefully the instruction reported in this section before installing, powering, operating or servicing the product and observe the indications also for its future handling.



**This unit is not for household use, only professional applications.**



## Connection to mains supply

- The Connection to the mains supply must be carried out by a qualified electrical installer.
- Use only AC supplies 100-240V 50-60 Hz, the fixture must be electrically connected to ground (earth).
- Select the cable cross section in according with the maximum current draw of the product and the possible number of products connected at the same power line.
- The AC mains power distribution circuit must be equipped with magnetic+residual current circuit breaker protection.
- Do not connect it to a dimmer system; doing so may damage the product.



## Protection and Warning against electrical shock

- Do not remove any cover from the product, always disconnect the product from AC power before servicing.
- Ensure that the fixture is electrically connected to ground (earth). And use only a source of AC power that complies with local building and electrical codes and has both overload and ground-fault (earth-fault) protection.
- Before using the fixture, check that all power distribution equipment and cables are in perfect condition and rated for the current requirements of all connected devices.
- Isolate the fixture from power immediately if the power plug or any seal, cover, cable, or other components are damaged, defective, deformed or showing signs of overheating.
- Do not reapply power until repairs have been completed.
- Refer any service operation not described in this manual to PROLIGHTS Service team or an authorized PROLIGHTS service center.



## Installation

- Make sure that all visible parts of the product are in good visible condition before its use or installation.
- Make sure the point of anchorage is stable before positioning the projector.
- When suspending the fixture above ground level, secure it against failure of primary attachments by attaching a safety cable that is approved as a safety attachment for the weight of the fixture to the attachment point on the main frame of the product. In case the safety cable, enter in action, it needs to be replaced with a new one.
- Install the product only in well ventilated places.
- For non temporary installations, ensure that the fixture is securely fastened to a load-bearing surface with suitable corrosionresistant hardware.
- For a temporary installation with clamps, ensure that the quarter-turn fastener and/or screws are turned fully, and secured with a suitable safety cable.



## Minimum distance of illuminated objects

- The projector needs to be positioned so that the objects hit by the beam of light are at least 0.3 meters (0.98 ft) from the lens of the projector.

**T<sub>a</sub> 45°C**

**Max operating ambient temperature (T<sub>a</sub>)**

- Do not operate the fixture if the ambient temperature (T<sub>a</sub>) exceeds 45 °C (113 °F).

**T<sub>a</sub> -10°C**

**Minimum operating ambient temperature (T<sub>a</sub>)**

- Do not operate the fixture if the ambient temperature (T<sub>a</sub>) is below -10 °C (14 °F).



**Protection from burns and fire**

- The exterior of the fixture becomes hot during use. Avoid contact by persons and materials.
- Ensure that there is free and unobstructed airflow around the fixture.
- Keep flammable materials well away from the fixture.
- Do not expose the front glass to sunlight or any other strong light source from any angle. Lenses can focus the sun's rays inside the fixture, creating a potential fire hazard.
- Do not attempt to bypass thermostatic switches or fuses.



**Indoor use**

- This product is designed for indoor and dry environments.
- Do not use in wet location and do not expose the fixture to rain or moisture.
- Never use the fixture in places subject to vibrations or bumps.
- Make certain that no inflammable liquids, water or metal objects enter the fixture.
- Excessive dust, smoke fluid, and particle build up degrades performance, causes overheating and will damage the fixture.
- Damages caused by inadequate cleaning or maintenance are not covered by the product warranty.



**Light collimation optical system\***

- This product contains internal light collimation optical system. Avoid to expose the optical system to any intense source of light (including sunlight) from any angle.

**T<sub>c</sub> 70°C**

**Temperature of the external surface**

- The surface of the fixture can reach up to 70 °C (158 °F) during operation. Avoid contact with people and materials.



**Lamp\***

The fitting mounts a high-pressure lamp that needs an external ignitor. This ignitor is fitted onto the apparatus.

1. Carefully read the "operating instructions" provided by the lamp and ignitor manufacturer.
2. Immediately replace the lamp if damaged or deformed by heat.



**Photobiological safety**

- This device emits potentially dangerous optical radiation and is identified in the category of Risk Group 2 according to EN 62471.



**Radio receiver\***

- This product contains a radio receiver and/or transmitter:
- Maximum output power: 17 dBm.
- Frequency band: 2.4 GHz.



### Maintenance

- Warning! Disconnect the fixture from AC mains power and allow to cool for at least 10 minutes before handling.
- Only technicians who are authorized by PROLIGHTS or Authorised service partners are permitted to open the fixture.
- Users may carry out external cleaning, following the warnings and instructions provided, but any service operation not described in this manual must be referred to a qualified service technician.
- Important! Excessive dust, smoke fluid, and particle build up degrades performance, causes overheating and will damage the fixture. Damages caused by inadequate cleaning or maintenance is not covered by the product warranty.



### Do not stare at the operating light source

- Do not look directly at the LED source during operation. It can be harmful to the eyes and skin.
- During Installation, operation and maintenance, be prepared for the fixture to light and move suddenly when connected to power.
- The device should be positioned so that prolonged staring into the luminaire at a distance closer than 2.687 m (8.815 ft) is not expected.

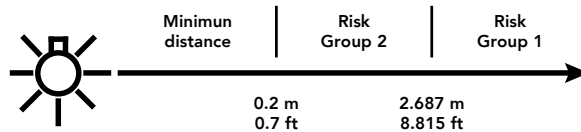

### Disposal

- This product is supplied in compliance with European Directive 2012/19/EU – Waste Electrical and Electronic Equipment.
- (WEEE). To preserve the environment please dispose/ recycle this product at the end of its life according to the local regulation.



### The product contains a lithium ion battery

- Don't throw the unit into the garbage at the end of its lifetime.
- Make sure to dispose according to your local ordinances and/or regulations, to avoid polluting the environment!
- The packaging is recyclable and can be disposed.



### The products to which this manual refers comply with:

- 2014/35/EU - Safety of electrical equipment supplied at low voltage (LVD);
- 2014/30/EU - Electromagnetic Compatibility (EMC);
- 2011/65/EU - Restriction of the use of certain hazardous substances (RoHS);
- 2014/53/EU - Radio Equipment Directive (RED).

# 1 - PACKAGING

## PACKAGE CONTENT

- 1x ASTRAWASH19PIX;
- 1x 1,5 meters power cable (SCHUKO plug - SEETRONIC IP65 power connector);
- 2x OS24;
- User Manual.

## OPTIONAL ACCESSORIES

- FCLASTRAW19PIX: flight case for 4 pcs of ASTRAWASH19PIX;
- ASTRAW19PEC: egg crate for ASTRAWASH19PIX;
- WSPBF2500G5: proBox F-2500 G5 transmitter, 1024Ch 90-250VAC, 19;
- WSBBF2G5: blackBoxF-2 G5 transmitter, 2,45GHz & 5.2/5,8 GHz, DMX/RDM, 1024Ch;
- WSBBF1G5: blackBox F-1 G5 transmitter, 2,45GHz & 5.2/5,8 GHz, DMX/RDM, 512Ch;
- MICROF1G5: micro F-1 G5 transmitter, int. omni antenna 2dBi, 2,45GHz. 512Ch, 12VDC, Batt.;
- OS24: quick-lock omega bracket;
- C6002: slim aluminium clamp, 200 kg loading, 48-51 mm tubes, M10 bolt;
- RSR0630A/B: steel security cable for hanging bodies, inox steel shackle, L=60 cm, silver/black;
- UPBOX2: firmware uploader kit, USB IN, 3-pin XLR DMX OUT.

# 2 - TECHNICAL DRAWING

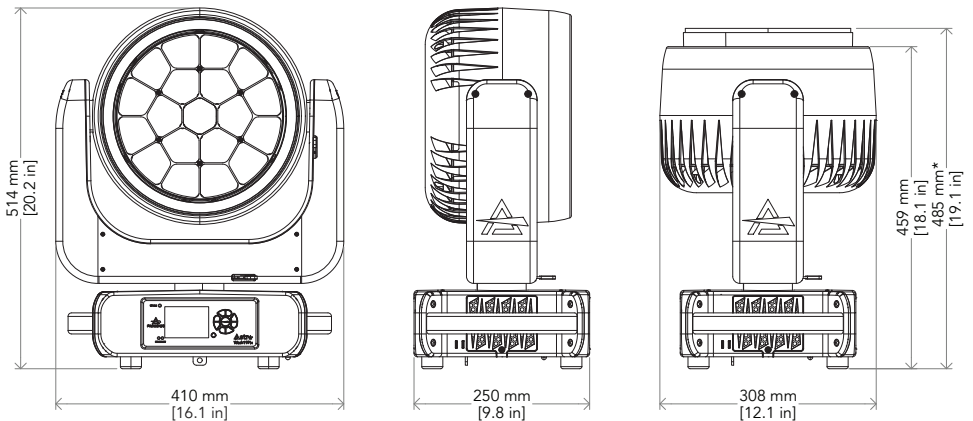

\* The measure includes the zoom.

Weight: 17.4 kg - 38.36 lbs

Fig. 01

# 3 - PAN AND TILT LOCK

PAN Mechanism lock and release

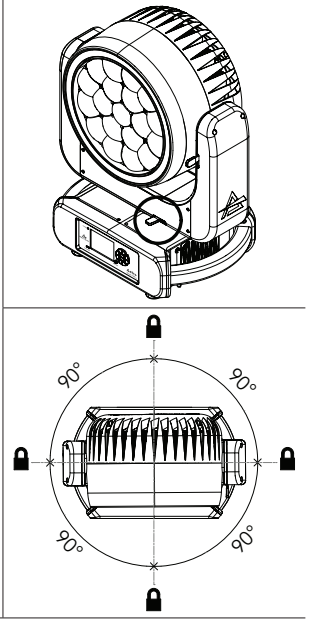
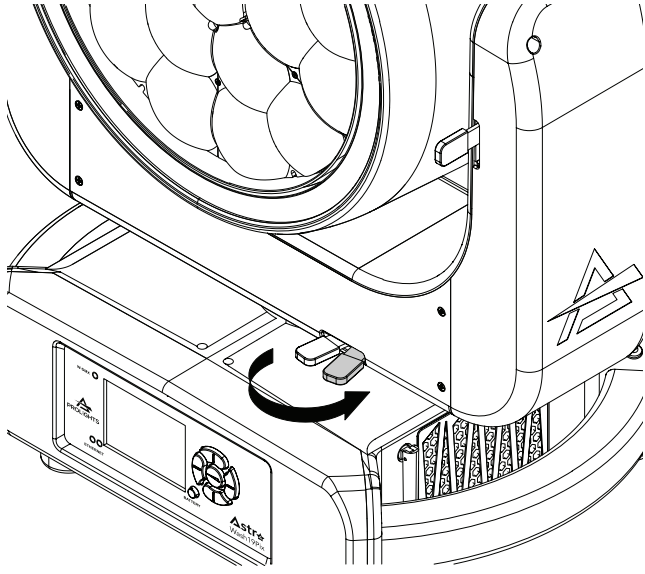

TILT Mechanism lock and release

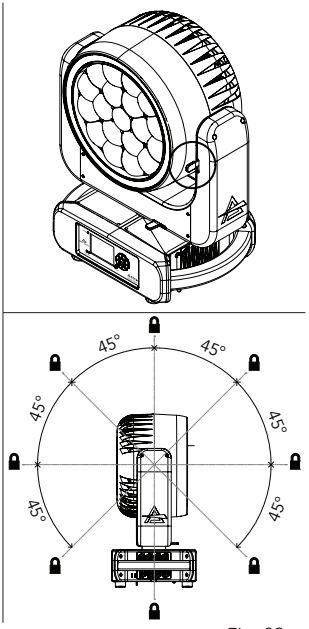
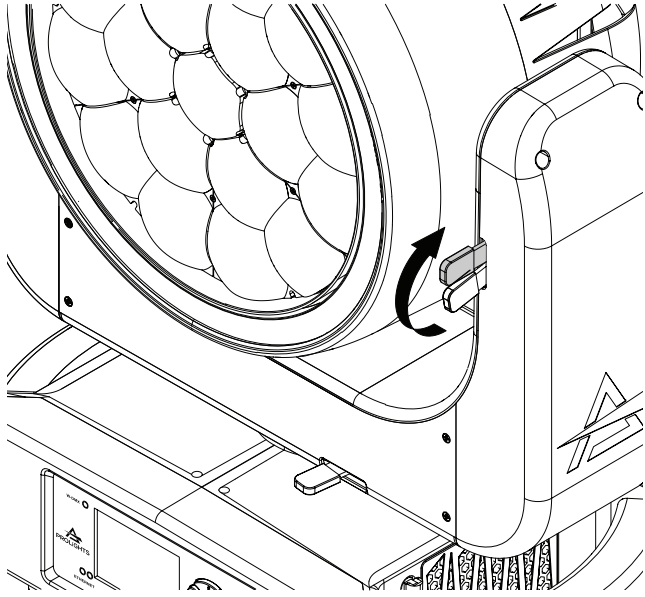

Fig. 02



# 4 - INSTALLATION

## MOUNTING

Check that the supporting structure can safely bear the weight of all installed fixtures, clamps, cables, auxiliary equipment, etc. and complies with locally applicable regulations.

When suspending the fixture above ground level, secure it against failure of primary attachments by attaching a safety wire that is approved as a safety attachment for the weight of the fixture to an anchor point on the product main frame.

Do not use removable parts or weak anchors for secondary attachment.

Warning! When clamping the fixture to a truss or other structure at any angle, use clamps of half-coupler type. Do not use any type of clamp that does not completely encircle the structure when fastened.

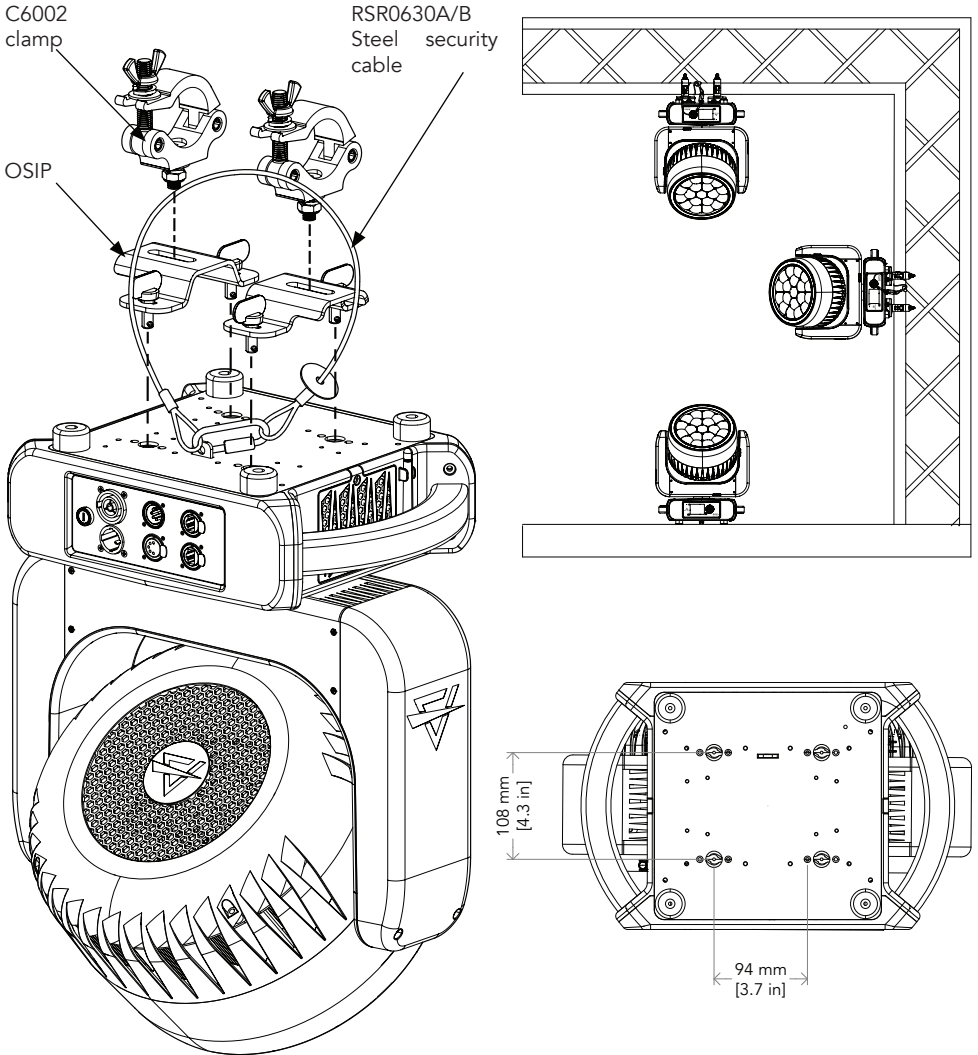

Dimensions are in mm / in - Fig.03

## 5 - CONNECTION TO THE MAINS SUPPLY

**WARNING:** For protection from electric shock, the fixture must be earthed!

The product is equipped with auto-switching power supply that automatically adjusts to any 50-60Hz AC power source from 100-240 Volts.

If you need to install a power plug on the power cable to allow connection to power outlets, install a grounding-type (earthed) plug, following the plug manufacturer's instructions. If you have any doubts about proper installation, consult a qualified electrician.

The max power consumption is 620W.

Core (EU)	Core (US)	Connection	Plug terminal marking
Brown	Black	Live	L
Blue	White	Neutral	N
Yellow+green	Green	Earth	

## 6 - START UP

### CONNECT AND DISCONNECT POWER FROM THE PRODUCT

To apply and disconnect power to the product:

- Check that the product is installed and secured as indicated in the Safety Informations, and that personal safety will not be put at risk when the fixture lights up.
- Connect the power connector into the Mains input socket (100-240 VAC-50/60 Hz).
- The product is then ready for its operations and can be controlled through the available input signals on board.
- To disconnect power from the product, disconnect the Mains from the socket.

## 7 - PRODUCT OVERVIEW

1. TILT Mechanism lock and release;
2. PAN Mechanism lock and release;
3. SAFETY EYE to attach safety cable;
4. USER INTERFACE with display and buttons for access to the control panel functions;
5. ANTENNA of Wireless DMX Receiver internal module.
6. ETHERCON CONNECTORS IN / OUT signal;
7. DMX IN (5-p XLR): 1 = GND, 2 = sign-, 3 = sign+, 4 N/C, 5 N/C;
8. DMX OUT (5-p XLR): 1 = GND, 2 = sign-, 3 = sign+, 4 N/C, 5 N/C;
9. POWER IN: for connection to the Mains 100-240V~/50-60Hz;
10. POWER OUT: power output for connection of multiple units in series;
11. MAIN FUSE HOLDER: replace a burnt-out fuse by one of the same type only (T8A 250V).

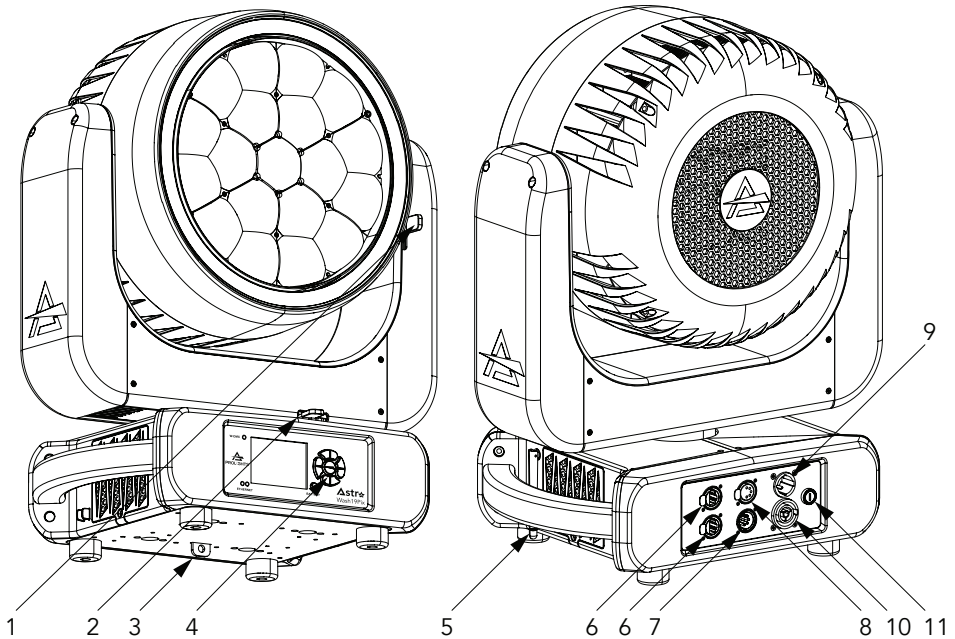

Fig 04

# 8 - DMX CONNECTION

## CONNECTION OF THE CONTROL SIGNAL: DMX LINE

The product has XLR sockets for DMX input and output.  
The default pin-out on both socket is as the following diagram:

### DMX - INPUT XLR plug



- Pin1 : GND - Shield
- Pin2 : - Signal
- Pin3 : + Signal
- Pin4 : N/C
- Pin5 : N/C

### DMX - OUTPUT XLR socket

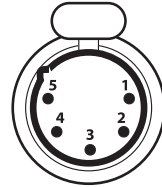

Fig. 05

## INSTRUCTIONS FOR A RELIABLE DMX CONNECTION

Use shielded twisted-pair cable designed for RS-485 devices: standard microphone cable cannot transmit control data reliably over long runs. 24 AWG cable is suitable for runs up to 300 meters (1000 ft). Heavier gauge cable and/or an amplifier is recommended for longer runs.  
To split the data link into branches, use splitter-amplifiers in the connection line.  
Do not overload the link. Up to 32 devices may be connected on a serial link.

## CONNECTION DAISY CHAIN

Connect the DMX data output from the DMX source to the product DMX input (male connector XLR) socket.  
Run the data link from the product XLR output (female connector XLR) socket to the DMX input of the next fixture.  
Terminate the data link by connecting a 120 Ohm signal termination. If a splitter is used, terminate each branch of the link.  
Install a DMX termination plug on the last fixture on the link.

## CONNECTION OF THE DMX LINE

DMX connection employs standard XLR connectors. Use shielded pair-twisted cables with 120Ω impedance and low capacity.  
The following diagram shows the connection mode:

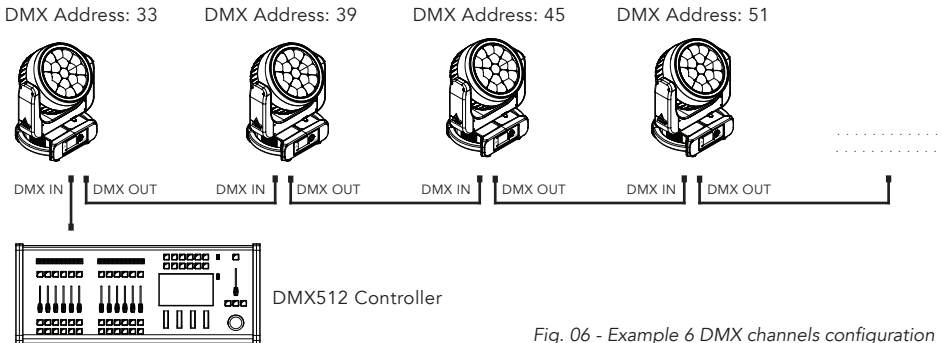

Fig. 06 - Example 6 DMX channels configuration

## CONSTRUCTION OF THE DMX TERMINATION

The termination is prepared by soldering a 120Ω 1/4 W resistor between pins 2 and 3 of the male XLR connector, as shown in figure.

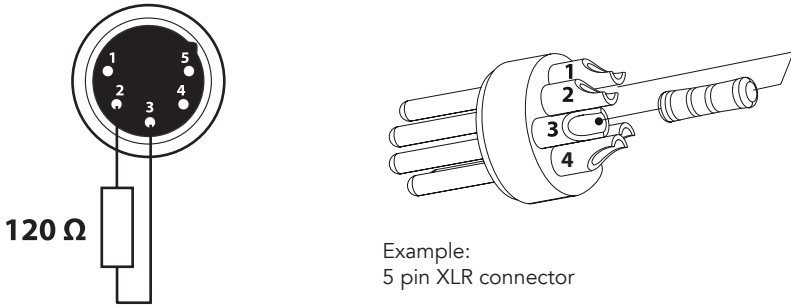

Fig. 07

## DMX ADDRESSING

In order to start controlling the product via DMX, the first step is to select a DMX address, also known as the start channel, this is the first channel used to receive instructions from a DMX controller. If you wish to control the product individually, it is necessary to assign a different starting address channel to each fixture.

The number of channels occupied from the product depends on the DMX mode selected, so always verify the DMX Mode in the MENU before start addressing.

If you assign two fixtures the same address, they will be executing the same behaviour. Selecting the same address to multiple fixtures can be useful for diagnostic purposes and symmetrical control.

DMX addressing is limited to make it impossible to set the DMX address so high that you are left without enough control channels for the product.

To set the fixture's DMX address:

1. Press ENTER to open the main menu.
2. Reach the addressing menu, then select the DMX ADDRESS settings.
3. Select the address from 1 to 512 using the navigation arrows/buttons and confirm by pressing ENTER.
4. Press Menu to exit and return to the Home screen.

## ETHERNET CONNECTION

The products is provided with two 8-pin RJ-45 sockets for Ethernet input/output for a simple daisy chain connection to the network.

The product can be controlled with ArtNet (or others available) communication protocol.

Use a network cable category 5 (with four "twisted" wire pairs) and standard RJ-45 plugs.

## ETHERNET OPERATION

Please refer to the section MENU STRUCTURE contained in this document for detailed informations about the parameters of setting on the fixture (Protocol, Net, Subnet, Universe, Start Channel and IP Address, Ethernet to DMX No/Yes).

- About the IP addresses is recommended to set 002.xxx.xxx.xxx or 010.xxx.xxx.xxx.
- The submask net is fixed at 255.0.0.0.

## ETHERNET TO DMX OPERATIONS

Please refer to the section MENU STRUCTURE contained in this document for detailed informations. This function allow a product receiving an ethernet signal protocol to re-transmit the incoming signal onto a wired DMX line through its onboard XLR-out connector.

- An Ethernet protocol (Artnet, sACN or others available) has to be enabled from Ethernet menu at first fixture. **Please make sure that wireless receiver is switched to OFF if you use Ethernet communication.**
- Enable the option Ethernet To DMX from the Ethernet menu at the first product (connected to the Ethernet) in the signal chain, next products have standard DMX setting.
- Connect the Ethernet input of the first product in the data chain with the network. Connect the DMX output of this product with the input of the next product until all products are connected to the DMX chain.
- Caution: At the last product, the DMX chain has to be terminated with a terminator. Solder a 120  $\Omega$  resistor between Signal (-) and Signal (+) into a XLR-plug and connect it in the DMX-output of the last product.

## OPERATION AS A WIRELESS TRANSMITTER

ASTRAWASH19PIX can be used as wireless transmitter to transmit DMX signal to different wireless receivers. To use ASTRAWASH19PIX as wireless transmitter, please follow the procedure below:

1. Push ENTER button until you show CONNECT on display, then press ENTER button to confirm.
  2. Use UP/DOWN buttons for select WIRELESS, then press ENTER to confirm.
  3. Push ENTER button on WDMX ON/OFF function and enable it to ON.
  4. Select WDMX mode and set it on Transmitter (please note that WDMX mode will be available only if WDMX ON/OFF is set to ON).
  5. Ensure that the receiver units are not connected to any other transmitter. Please refer to "Reset the receiver" paragraph.
  6. Enable TX LINK to ON to link transmitter to receivers (please note that TX LINK will be available only if WDMX mode is set to Transmitter).
- The transmitter scans for all unlinked receivers for a period of about 5 seconds.
  - If the connection fails, check the position of the receiver.
  - The wireless icon on the receiver display indicates the received signal strength.

## Unlinking the transmitter

Follow the procedure below to unlink the transmitter from all receivers connected with the unit.

1. Push ENTER button until you show CONNECT on display, then press ENTER button to confirm.
  2. Use UP/DOWN buttons for select Wireless, then press ENTER to confirm.
  3. Enable TX UNLINK to ON 8 (please note that TX UNLINK will be available only if WDMX mode is set to Transmitter).
- All connected receivers will be unlinked.

## IN TO WDMX

This function enable or disable the transmission through wireless of the DMX signal from the transmitter side to the receiver.

Any incoming signal (ArtNet, sACN or DMX) is retransmitted through wireless.

If the ASTRAWASH19PIX protocol selected is ArtNet / sACN, the WDMX module will retransmit the DMX values contained in the ArtNet / sACN signal received from the ASTRAWASH19PIX.

**NOTE:** Artnet and sACN have higher priority on DMX if they are connected to transmitter.

## **OPERATION AS A WIRELESS RECEIVER**

ASTRAWASH19PIX can be used as wireless receiver connected to a wireless transmitter.

To use ASTRAWASH19PIX as wireless receiver, please follow the procedure below:

1. Push ENTER button until you show CONNECT on display, then press ENTER button to confirm.
2. Use UP/DOWN buttons for select Wireless, then press ENTER to confirm.
3. Push ENTER button on WDMX ON/OFF function and enable it to ON.
4. Select WDMX mode and set it on Receiver (please note that WDMX mode will be available only if WDMX ON/OFF is set to ON).
5. Enable RX RESET to ON to reset the receiver (please note that RX RESET will be available only if WDMX mode is set to Receiver).
6. On the transmitter, enable TX LINK to ON to link transmitter to the receivers.
7. If the connection is successful and DMX input is available the display the display on the receiver unit will shows the DMX address. If DMX signal is not available, the display will shows "No signal" but keeps the transmitter linked.
8. If the connection fails, check the position of the receiver.
9. The wireless icon on the receiver display indicates the received signal strength.

### **Reset the receiver**

Follow the procedure below to reset the receiver.

1. Push MENU button until you show CONNECT on display, then press ENTER button to confirm.
2. Use UP/DOWN buttons for select Wireless, then press ENTER to confirm.
3. Enable RX RESET to ON.
  - The wireless icon on the receiver display indicates the received signal strength.

### **WDMX TO DMX (RX)**

This function enable or disable the retransmission of the wireless DMX signal received through the DMX port on the receiver side.

# 9 - CONTROL PANEL

The product has a display and buttons for access to the control panel functions.

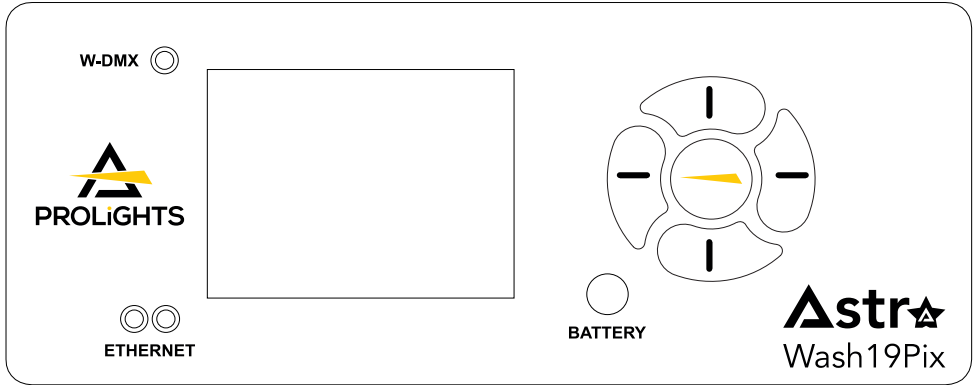

Fig. 08

## DISPLAY AND BUTTONS LAYOUT

The product has a display and buttons for access to the control panel functions:

	1		<ul style="list-style-type: none"> <li>Browse upwards through the menu list and increases the numeric value displayed.</li> </ul>
	2		<ul style="list-style-type: none"> <li>Return to the top level.</li> </ul>
	3		<ul style="list-style-type: none"> <li>Browse downwards through the menu list and decreases the numeric value displayed.</li> </ul>
	4		<ul style="list-style-type: none"> <li>Commute from units, tens, hundred in the menu.</li> </ul>
	5		<ul style="list-style-type: none"> <li>Used to access the menu tree or to return a previous menu window.</li> </ul>
			<ul style="list-style-type: none"> <li>To switch on the display through the battery.</li> </ul>
<b>W-DMX</b>			<ul style="list-style-type: none"> <li>LED indicator for Wireless dmx (color red and green).</li> </ul>
			<ul style="list-style-type: none"> <li>LED indicator for Ethernet network.(color orange).</li> </ul>



# 10 - MENU STRUCTURE

The following chart describes the MENU tree of the product, the terms shown in **BOLD** indicates the default settings.

MENU						
1	CONNECT	ADDRESS	FIXTURE	DMX / WDMX	<b>001-512</b>	
				sACN	<b>001-512</b>	
				ARTNET	<b>001-512</b>	
			PIXELS	FOLLOW FIXTURE	<b>001-512</b>	
				DMX / WDMX	<b>001-512</b>	
				sACN	<b>001-512</b>	
				ARTNET	<b>001-512</b>	
				sACN + KLINGNET	<b>001-512</b>	
				ARTNET + KLINGNET	<b>001-512</b>	
		DMX MODE	FIXTURE	BASIC		Set DMX chart for Main Fixture.
				FX		
				<b>STANDARD</b>		
				EXTENDED		
			PIXELS	<b>OFF</b>		Set DMX chart for Pixel Fixture.
				RING		
		PIXELS				
		WIRELESS	WDMX ON/OFF	ON/ <b>OFF</b>		Enable/Disable the wireless card.
			WDMX MODE	TRANSMITTER/ <b>RECEIVER</b>		Allows to choose whether to set the wireless on the Transmitter or Receiver. WDMX mode is unlocked only if WDMX ON / OFF is ON.
			TX LINK	ON/ <b>OFF</b>		TX link unlock when the unit is set as a transmitter..
			TX UNLINK	ON/ <b>OFF</b>		Disconnect the transmitter from all receivers. TX unlink unlocks only if WDMX mode is on transmitter
			RX RESET	ON/ <b>OFF</b>		Total reset of the receiver. RX reset unlocks only if WDMX mode is receiver.
			IN TO WDMX (TX)	<b>ON</b> /OFF		Enable/Disable the transmission of the dmx from the transmitter to the receiver via wdmx.
			WDMX TO DMX (RX)	<b>ON</b> /OFF		Enable/Disable the retransmission of the DMX from the receiver to the other units connected by cable to the receiver itself

	ETHERNET SETTING	ARTNET SETTINGS	IP ADDRESS		Set IP address of the fixture.			
			NET		Set Net for ArtNet protocol.			
			SUBNET		Set Subnet for ArtNet protocol.			
			UNIVERSE		Set Universe for ArtNet protocol.			
		sACN SETTINGS	IP ADDRESS		Set IP address of the fixture.			
			UNIVERSE		Set Universe for sACN protocol.			
			MERGE MODE	OFF/HTP/LTP	Set Merge Mode for sACN protocol.			
		ETHERNET TO DMX	ON		Enable / Disable DMX retrasmision from sACN/ ArtNet signal to DMX out port.			
			OFF					
		KLINGNET	ON		Enable / Disable Klingnet functionality for sACN / ArtNet protocols.			
			OFF					
		2	SETUP	SCREEN	BACKLIGHT	ON	Allows you to select the timing after that display will switch automatically off when inactive.	
						10 s		
						20 s		
30 s								
FLIP DISPLAY	ON				Allows you to rotate the display by 180°.			
	OFF							
	AUTO							
KEY LOCK	ON				Allows you lock the buttons on the control panel by a password. Press following combinations (password) in order to access to the user menu : UP, DOWN, UP, DOWN.			
	OFF							
MOVEMENT	PAN REVERSE				ON	Allows you to reverse Pan movement.		
				OFF				
	TILT REVERSE			ON	Allows you to reverse Tilt movement.			
				OFF				
	PAN/TILT FEEDBACK			ON	To activate / deactivate the reading of the feedbacks given by the encoders.			
		OFF						
	PAN/TILT MODE	SLOW	To choose the horizontal/vertical movement speed.					
		MEDIUM						
		FAST						
	HOME POSITION	STANDARD	To choose the home position.					
CUSTOM								
CUSTOM P DEGREE	0°	To choose pan values in case of Custom position.						
	...							
	315°							
CUSTOM T DEGREE	0%	To choose tilt values in case of Custom position.						
	...							
	100%							

		<b>FIXTURE SETTINGS</b>	FAN MODE	AUTO		Select Fan behaviour.
				SILENT		
				HIGH		
			WHITE CALIBRATION	OFF		Manufacturer calibration to grant performance and color consistency.
				STUDIO		
				8000K		
			DMX FAULT	HOLD		To choose the behaviour of fixture in case of dmx signal lost.
				BLACKOUT		
			STATUS LED	ON		To turn the status LEDs on the front panel on or off.
				OFF		
			ZOOM MODE	STANDARD		Select zoom mode.
				PIXELS		
			DIMMER CURVE	LINEAR		Select different curve behaviour of dimmer
				S-CURVE		
				SQUARE LAW		
				INV. SQUARE LAW		
			DIMMER SPEED	AUTO		Linear dimmer behaviour.
				FAST		Dimmer curve adding long fade.
				MEDIUM		Dimmer curve adding medium fade.
				SLOW		Dimmer curve adding little fade.
			LED FREQUENCY	600Hz		Select PWM frequency.
				1200Hz		
				2000Hz		
				4000Hz		
				6000Hz		
				25KHz		
				50KHz		
			INVERT MAPPING	ON		Invert mapping for Pixel fixture.
				OFF		
			INVERT ZOOM	ON		Invert zoom values.
OFF						
TRANSFER CONFIGURATION	WITHOUT DMX ADDRESS		To transfer the same menu settings of one fixtures to all the other in the daisy chain, including or not the dmx address.			
	WITH DMX ADDRESS					
3	ADVANCED	RESET	ALL			To reset these functions.
			PAN & TILT			
			ZOOM			

	CALIBRATION	PASSWORD			For the calibration of these functions. 050 password for user reset.	
		PAN				
		TILT				
		...				
	MANUAL CONTROL	PAN			For manual control of the unit.	
		...				
	RELOAD DEFAULT	BASIC RELOAD	ON		050 password for user reset.	
			OFF			
		ALL RELOAD	ON			
			OFF			
4 INFORMATION	FIXTURE TIME	FIXTURE HOURS	TOTAL	(ONLY READ)	To check the total working hours of the unit.	
			PARTIAL	(READ AND RESET)		
		CURRENT HOURS	TOTAL	(ONLY READ)	To check the current working hours of the unit.	
			PARTIAL	(READ AND RESET)		
		SOURCE HOURS	TOTAL	(ONLY READ)	To see the total operating hours of the LED source.	
			PARTIAL	(READ AND RESET)		
		POWER ON CYCLE	TOTAL	(ONLY READ)	To see the power cycles of the machine.	
			PARTIAL	(READ AND RESET)		
		MAINTENANCE TIME	ELAPSED TIME		To choose and reset unit maintenance warning hours.	
			ALERT PERIOD	10 - 300		
		TEMPERATURE	NEAR SOURCE TEMP, DRIVER PCB TEMP, LED PCB TEMP,...			To see the unit temperature.
		FANS SPEED	NEAR SOURCE FAN, BASE FAN,...			To see the speed of the fans.
	WIRELESS QUALITY				To check the wireless quality.	
	CHANNEL VALUE	PAN...			To see the dmx value of those channels.	
	ERROR MESSAGE	PAN, TILT...			To see any error messages.	
	FIXTURE MODEL	XXXXXXXXXX			View informations about fixture model.	
	RDM UID	(READ AND RESET)			View ID for the RDM control.	
	SOFTWARE VERSION	1U01 V1.0.00...			View informations about software version.	

# 11 - SHORTCUT

KEYS	MODE	DESCRIPTION
UP + DOWN after power on	Flip Display	Directly flip display without enter inside menu.
DOWN then power on	Reset without pan/tilt movements	Fixture will be powered on without reset on pan/tilt movements.
ENTER + UP then power on	Bootloader	Force firmware upgrade.

## 12 - RDM FUNCTIONS

The product can communicate using RDM (Remote Device Management) protocol over a DMX512 Networks.

RDM is a bi-directional communications protocol for use in DMX512 control systems, it is the open standard for DMX512 device configuration and status monitoring.

The RDM protocol allows data packets to be inserted into a DMX512 data stream without affecting existing non-RDM equipment. It allows a console or dedicated RDM controller to send commands to and receive messages from specific fixtures.

The PIDs in the following tables are supported in the product.

RDM is also available on Wireless and Tiny's Downstead must be enabled in its custom PIDs to work.

Category	Parameter	PID	GET	SET
<b>Product Information</b>	DEVICE_INFO	0x0060	x	
	PRODUCT_DETAIL_ID_LIST	0x0070	x	
	DEVICE_MODEL_DESCRIPTION	0x0080	x	
	MANUFACTURER_LABEL	0x0081	x	
	DEVICE_LABEL	0x0082	x	x
	FACTORY_DEFAULTS	0x0090	x	x
	SOFTWARE_VERSION_LABEL	0x00C0	x	
	BOOT_SOFTWARE_VERSION_ID	0x00C1	x	
	BOOT_SOFTWARE_VERSION_LABEL	0x00C2	x	
<b>DMX512 Setup</b>	DMX_PERSONALITY	0x00E0	x	x
	DMX_PERSONALITY_DESCRIPTION	0x00E1	x	
	DMX_START_ADDRESS	0x00F0	x	x
	SLOT_INFO	0x0120	x	
	SLOT_DESCRIPTION	0x0121	x	
	DEFAULT_SLOT_VALUE	0x0122	x	
	DMX_BLOCK_ADDRESS	0x0140	x	x
	DMX_FAIL_MODE	0x0141	x	x
DMX_STARTUP_MODE	0x0142	x	x	
<b>Dimmer Settings</b>	DIMMER_INFO	0x0340	x	
	MINIMUM_LEVEL	0x0341	x	x
	MAXIMUM_LEVEL	0x0342	x	x
	CURVE	0x0343	x	x
	CURVE_DESCRIPTION	0x0344	x	x
	OUTPUT_RESPONSE_TIME	0x0345	x	x
	OUTPUT_RESPONSE_TIME_DESCRIPTION	0x0346	x	
	MODULATION_FREQUENCY	0x0347	x	x
	MODULATION_FREQUENCY_DESCRIPTION	0x0348	x	
<b>Sensors</b>	SENSOR_DEFINITION	0x0200	x	
	SENSOR_VALUE	0x0201	x	x
	RECORD_SENSORS	0x0202		x
	BURN_IN	0x0440	x	x

<b>Power/Lamp Settings</b>	DEVICE_HOURS	0x0400	x	x
	LAMP_HOURS	0x0401	x	x
	LAMP_STRIKES	0x0402	x	x
	LAMP_STATE	0x0403	x	x
	LAMP_ON_MODE	0x0404	x	x
	DEVICE_POWER_CYCLES	0x0405	x	x
<b>Display Settings</b>	DISPLAY_INVERT	0x0500	x	x
	DISPLAY_LEVEL	0x0501	x	x
<b>Configuration</b>	PAN_INVERT	0x0600	x	x
	TILT_INVERT	0x0601	x	x
	PAN_TILT_SWAP	0x0602	x	x
	REAL_TIME_CLOCK	0x0603	x	x
	LOCK_PIN	0x0640	x	x
	LOCK_STATE	0x0641	x	x
	LOCK_STATE_DESCRIPTION	0x0642	x	
<b>Control</b>	IDENTIFY_DEVICE	0x1000	x	x
	RESET_DEVICE	0x1001		x
	POWER_STATE	0x1010	x	x
	PERFORM_SELFTEST	0x1020	x	x
	SELF_TEST_DESCRIPTION	0x1021	x	
	CAPTURE_PRESET	0x1030	x	x
	PRESET_PLAYBACK	0x1031	x	x
	IDENTIFY_MODE	0x1040	x	x
	PRESET_INFO	0x1041	x	
	PRESET_STATUS	0x1042	x	x
	PRESET_MERGEMODE	0x1043	x	x
	POWER_ON_SELF_TEST	0x1044	x	x
<b>IP &amp; DNS Configuration</b>	IPV4_CURRENT_ADDRESS	0x0705	x	
	IPV4_STATIC_ADDRESS	0x0706	x	x
<b>Custom Pids</b>	FIX. ENGINE PROT. (0:W/DMX 1:sACN 2:ArtNet)	TBD	x	x
	PIX. ENGINE PROT. (0:W/DMX 1:sACN 2:ArtNet 3:sAK 4:ArtK)	TBD	x	x
	PIX. ENGINE ADDR. (1-512)	TBD	x	x
	PIX. ENGINE MODE (0:Off 1:Ring 2:Pixel)	TBD	x	x
	KLINGNET (0:Off 1:On)	TBD	x	x

# 13 - DMX CHARTS

## Fixture Engine

Channel	Basic	FX	Standard	Extended
1	Pan	Pan	Pan	Pan
2	Pan Fine	Pan Fine	Pan Fine	Pan Fine
3	Tilt	Tilt	Tilt	Tilt
4	Tilt Fine	Tilt Fine	Tilt Fine	Tilt Fine
5	Dimmer	Dimmer	Dimmer	Dimmer
6	Dimmer Fine	Dimmer Fine	Dimmer Fine	Dimmer Fine
7	Shutter / Strobe	Shutter / Strobe	Shutter / Strobe	Shutter / Strobe
8	Red	Red	Red	Red
9	Green	Green	Red Fine	Red Fine
10	Blue	Blue	Green	Green
11	White	White	Green Fine	Green Fine
12	Color Macro	CTC	Blue	Blue
13	CTC	Zoom	Blue Fine	Blue Fine
14	Zoom	Crossfade from Artnet to Klingnet	White	White
15	Crossfade from Artnet to Klingnet	Crossfade for Pixel Engine	White Fine	White Fine
16	Crossfade for Pixel Engine	Crossfade from White to Color	Color Macro	Color Macro
17	Crossfade from White to Color	Control	CTC	CTC
18	Control	Pattern	Zoom	Zoom
19	Ring Foreground Intensity	Pattern Speed	Zoom Fine	Zoom Fine
20	Ring Foreground Strobe	Pattern Fade	Crossfade from Artnet to Klingnet	Crossfade from Artnet to Klingnet
21	Ring Foreground Red	Pattern Transition	Crossfade for Pixel Engine	Crossfade for Pixel Engine
22	Ring Foreground Green	Foreground Intensity	Crossfade from White to Color	Crossfade from White to Color
23	Ring Foreground Blue	Foreground Strobe	Control	Control
24		Background Intensity	CTO on colors	CTO on colors
25		Background Strobe	Tint	Tint
26		Background Red	Ring Foreground Intensity	Pattern
27		Background Green	Ring Foreground Strobe	Pattern Speed
28		Background Blue	Ring Foreground Red	Pattern Fade
29		Background White	Ring Foreground Green	Pattern Transition
30		Ring Dimmer	Ring Foreground Blue	Foreground Intensity
31		Ring Pattern		Foreground Strobe
32		Ring Pattern Speed		Background Intensity
33		Ring Pattern Fade		Background Strobe
34		Ring Pattern Transition		Background Red
35		Ring Foreground Intensity		Background Green



Channel	Basic	FX	Standard	Extended
36		Ring Foreground Strobe		Background Blue
37		Ring Foreground Red		Background White
38		Ring Foreground Green		Ring Dimmer
39		Ring Foreground Blue		Ring Pattern
40		Ring Background Intensity		Ring Pattern Speed
41		Ring Background Strobe		Ring Pattern Fade
42		Ring Background Red		Ring Pattern Transition
43		Ring Background Green		Ring Foreground Intensity
44		Ring Background Blue		Ring Foreground Strobe
45				Ring Foreground Red
46				Ring Foreground Green
47				Ring Foreground Blue
48				Ring Background Intensity
49				Ring Background Strobe
50				Ring Background Red
51				Ring Background Green
52				Ring Background Blue

### Pixel Engine

Channel	Off	Ring	Pixel
1		Red 1	Red 1
2		Green 1	Green 1
3		Blue 1	Blue 1
4		White 1	White 1
5		Red 2	Red 2
6		Green 2	Green 2
7		Blue 2	Blue 2
8		White 2	White 2
9		Red 3	Red 3
10		Green 3	Green 3
11		Blue 3	Blue 3
12		White 3	White 3
...	...	...	...
73			Red 19
74			Green 19
75			Blue 19
76			White 19

Bas	FX	Std	Ext	Function	DMX Value	Default
1	1	1	1	<b>PAN</b> Lineary from 0% to 100%	000 ÷ 255	128
2	2	2	2	<b>PAN FINE</b> Lineary from 0% to 100%	000 ÷ 255	128
3	3	3	3	<b>TILT</b> Lineary from 0% to 100%	000 ÷ 255	128
4	4	4	4	<b>TILT FINE</b> Lineary from 0% to 100%	000 ÷ 255	128
5	5	5	5	<b>DIMMER</b> Lineary from close to open	000 ÷ 255	000
6	6	6	6	<b>DIMMER FINE</b> Lineary from close to open	000 ÷ 255	000
7	7	7	7	<b>SHUTTER</b> Close Strobe from slow to fast Open Pulse in from slow to fast Open Pulse out from slow to fast Open Random from slow to fast Open	000 ÷ 001 002 ÷ 062 063 ÷ 064 065 ÷ 125 126 ÷ 127 128 ÷ 188 189 ÷ 190 191 ÷ 251 252 ÷ 255	255
8	8	8	8	<b>RED</b> Lineary from 0% to 100%	000 ÷ 255	255
			9	<b>RED FINE</b> Lineary from 0% to 100%	000 ÷ 255	255
9	9	10	10	<b>GREEN</b> Lineary from 0% to 100%	000 ÷ 255	255
		11	11	<b>GREEN FINE</b> Lineary from 0% to 100%	000 ÷ 255	255
10	10	12	12	<b>BLUE</b> Lineary from 0% to 100%	000 ÷ 255	255
		13	13	<b>BLUE FINE</b> Lineary from 0% to 100%	000 ÷ 255	255
11	11	14	14	<b>WHITE</b> Lineary from 0% to 100%	000 ÷ 255	255
		15	15	<b>WHITE FINE</b> Lineary from 0% to 100%	000 ÷ 255	255
12		16	16	<b>COLOR MACRO</b> Open Red Green Blue Cyan Magenta Yellow Dirty White Alice Blue Congo Blue Dark Steel Blue Deep Lavender Lilac Ting Daylight Blue Flame Red Bastard Amber Deep Orange Pale Gold Apricot Bright Blue Primary Green Special Lavender Pale Lavender Deep Golden Amber Medium Blue Bright Pink Mauve Dark Green Lee Green Dark Blue	000 ÷ 001 002 ÷ 003 004 ÷ 005 006 ÷ 007 008 ÷ 009 010 ÷ 011 012 ÷ 013 014 ÷ 015 016 ÷ 017 018 ÷ 019 020 ÷ 021 022 ÷ 023 024 ÷ 025 026 ÷ 027 028 ÷ 029 030 ÷ 031 032 ÷ 033 034 ÷ 035 036 ÷ 037 038 ÷ 039 040 ÷ 041 042 ÷ 043 044 ÷ 045 046 ÷ 047 048 ÷ 049 050 ÷ 051 052 ÷ 053 054 ÷ 055 056 ÷ 057 058 ÷ 059	000

Bas	FX	Std	Ext	Function	DMX Value	Default
12		16	16	<b>COLOR MACRO</b>		
				Light Blue	060 ÷ 061	
				Steel Blue	062 ÷ 063	
				Medium Blue+Green	064 ÷ 065	
				Peacock Blue	066 ÷ 067	
				Magenta	068 ÷ 069	
				Dark Pink	070 ÷ 071	
				Middle Rose	072 ÷ 073	
				Light Salmon	074 ÷ 075	
				English Rose	076 ÷ 077	
				Light Rose	078 ÷ 079	
				Orange	080 ÷ 081	
				Deep Amber	082 ÷ 083	
				Straw	084 ÷ 085	
				Light Amber	086 ÷ 087	
				Spring Yellow	088 ÷ 089	
				Dark Yellow Green	090 ÷ 091	
				Just Blue	092 ÷ 093	
				Sky Blue	094 ÷ 095	
				Lavender	096 ÷ 097	
				Light Lavender	098 ÷ 099	
				Pink Carnation	100 ÷ 101	
				Medium Pink	102 ÷ 103	
				Light Pink	104 ÷ 105	
				Sunset Red	106 ÷ 107	
				Dark Amber	108 ÷ 109	
				Gold Amber	110 ÷ 111	
				Medium Amber	112 ÷ 113	
				Fire	114 ÷ 115	
				Surprise Peach	116 ÷ 117	
				Straw Tint	118 ÷ 119	
				Medium Yellow	120 ÷ 121	
				Lee Minus Green	122 ÷ 123	
				Pale Gold	124 ÷ 125	
				Orange	126 ÷ 127	
				Deep Straw	128 ÷ 129	
				Rose Purple	130 ÷ 131	
				Deep Purple	132 ÷ 133	
				Soft Green	134 ÷ 135	
				Reserved	136 ÷ 211	
				2800K	212 ÷ 213	
3000K	214 ÷ 215					
3200K	216 ÷ 217					
3400K	218 ÷ 219					
3600K	220 ÷ 221					
3800K	222 ÷ 223					
4000K	224 ÷ 225					
4200K	226 ÷ 227					
4400K	228 ÷ 229					
4600K	230 ÷ 231					
4800K	232 ÷ 233					
5000K	234 ÷ 235					
5200K	236 ÷ 237					
5400K	238 ÷ 239					
5600K	240 ÷ 241					
6000K	242 ÷ 243					
6500K	244 ÷ 245					
7000K	246 ÷ 247					
8000K	248 ÷ 249					
9000K	250 ÷ 251					
10000K	252 ÷ 253					
Full On	254 ÷ 255					
13	12	17	17	<b>CTC</b> Linear from 2800K to 10000K	000 ÷ 255	000
14	13	18	18	<b>ZOOM</b> Lineary from 0% to 100%	000 ÷ 255	000
		19	19	<b>ZOOM FINE</b> Lineary from 0% to 100%	000 ÷ 255	000

Bas	FX	Std	Ext	Function	DMX Value	Default
15	14	20	20	<b>CROSSFADE FROM ArtNet/sACN TO Klingnet</b> Linear from Pixel Engine to Klingnet	000 ÷ 255	000
16	15	21	21	<b>CROSSFADE FROM Color Engine TO Pixel Engine</b> Linear from Color Engine to Pixel Engine	000 ÷ 255	000
17	16	22	22	<b>CROSSFADE FROM WHITE TO COLOR</b> Linear from CTC to Color engine	000 ÷ 255	000
18	17	23	23	<b>CONTROL</b> No Function KLINGNET ON KLINGNET OFF PAN REVERSE ON PAN REVERSE OFF TILT REVERSE ON TILT REVERSE OFF PAN/TILT MODE FAST PAN/TILT MODE MEDIUM PAN/TILT MODE SLOW PAN/TILT MODE SYNC MOVEMENT IN BLACKOUT ON MOVEMENT IN BLACKOUT OFF HOME POSITION STANDARD HOME POSITION CUSTOM DISPLAY ON DISPLAY 10S DISPLAY 20S DISPLAY 30S FLIP DISPLAY ON FLIP DISPLAY OFF FLIP DISPLAY AUTO KEY LOCK ON KEY LOCK OFF FAN MODE AUTO FAN MODE SILENT FAN MODE HIGH WHITE CALIBRATION OFF WHITE CALIBRATION STUDIO WHITE CALIBRATION 8000K NO SIGNAL HOLD NO SIGNAL BLACKOUT STATUS LED ON STATUS LED OFF DIMMER CURVE LINEAR DIMMER CURVE S+CURVE DIMMER CURVE SQUARE LAW DIMMER CURVE INVERSE SQUARE LAW DIMMER SPEED AUTO DIMMER SPEED FAST DIMMER SPEED MEDIUM DIMMER SPEED SLOW LED FREQUENCY 600HZ LED FREQUENCY 1200HZ LED FREQUENCY 2000HZ LED FREQUENCY 4000HZ LED FREQUENCY 6000HZ LED FREQUENCY 25KHZ LED FREQUENCY 50KHZ INVERT MAPPING ON INVERT MAPPING OFF ZOOM MODE STANDARD ZOOM MODE PIXELS INVERT ZOOM OFF INVERT ZOOM ON TUNGSTEN EMULATION ON TUNGSTEN EMULATION OFF RESET ALL RESET PAN RESET TILT RESET PAN/TILT RESET ZOOM Reserved FACTORY DEFAULT OF CONTROL FUNCTIONS	000 ÷ 001 002 ÷ 003 004 ÷ 005 006 ÷ 007 008 ÷ 009 010 ÷ 011 012 ÷ 013 014 ÷ 015 016 ÷ 017 018 ÷ 019 020 ÷ 021 022 ÷ 023 024 ÷ 025 026 ÷ 027 028 ÷ 029 030 ÷ 031 032 ÷ 033 034 ÷ 035 036 ÷ 037 038 ÷ 039 040 ÷ 041 042 ÷ 043 044 ÷ 045 046 ÷ 047 048 ÷ 049 050 ÷ 051 052 ÷ 053 054 ÷ 055 056 ÷ 057 058 ÷ 059 060 ÷ 061 062 ÷ 063 064 ÷ 065 066 ÷ 067 068 ÷ 069 070 ÷ 071 072 ÷ 073 074 ÷ 075 076 ÷ 077 078 ÷ 079 080 ÷ 081 082 ÷ 083 084 ÷ 085 086 ÷ 087 088 ÷ 089 090 ÷ 091 092 ÷ 093 094 ÷ 095 096 ÷ 097 098 ÷ 099 100 ÷ 101 102 ÷ 103 104 ÷ 105 106 ÷ 107 108 ÷ 109 110 ÷ 111 112 ÷ 113 114 ÷ 115 116 ÷ 117 118 ÷ 119 120 ÷ 121 122 ÷ 123 124 ÷ 253 254 ÷ 255	000

Bas	FX	Std	Ext	Function	DMX Value	Default
		24	24	<b>CTO ON COLORS</b> Lineary from 0% to 100%	000 ÷ 255	000
		25	25	<b>TINT</b> +25 % to +0 % magenta balanced +0 % to +25 % green	000 ÷ 127 128 129 ÷ 255	128
	18		26	<b>PATTERN</b> No FX All rings In & Out All rings In & Out Bouncing Single Ring In & Out Single Ring In & Out Bouncing All Pixels In & Out in Right Direction Single Line In & Out in Right Direction Single Line In & Out Bouncing in Left / Right Direction All Pixels In & Out in Bottom Direction Single Line In & Out in Bottom Direction Single Line In & Out Bouncing in Top / Bottom Direction Half Pixels rotating clockwise Fixture divided into 2 parts ring effect Random with 1px Density Random with 2px Density Random with 4px Density Random with 5px Density Random with 7px Density Pixel Going around Ring 1 Pixel Going around Ring 1 Pixel Going around Ring 2 Pixel Going around Ring 2 Pixel Going around Ring 2 Pixel Going around Ring 2 Clock rotating anti-clockwise Two squares rotating while moving from center Wiggling Line Two rotating 2x2px squares Pixels In & Out on Ring 2 side to side Triangle from 9 pixels rotate to right Wiggling clock 2 hands moving up and down Aperture effect Aperture Effect with 1 px only 2 Pixels Going around Ring 2 3 Pixels Going around Ring 2 Bottom Half Open / Close than Top Half Open Close Moving Fists Pixels coming in zigzak shape 2 Arc's rotating 2 2px wide lines rotating	000 ÷ 016 017 ÷ 022 023 ÷ 028 029 ÷ 034 035 ÷ 040 041 ÷ 046 047 ÷ 052 053 ÷ 058 059 ÷ 064 065 ÷ 070 071 ÷ 076 077 ÷ 082 083 ÷ 088 089 ÷ 094 095 ÷ 100 101 ÷ 106 107 ÷ 112 113 ÷ 118 119 ÷ 124 125 ÷ 130 131 ÷ 136 137 ÷ 142 143 ÷ 148 149 ÷ 154 155 ÷ 160 161 ÷ 166 167 ÷ 172 173 ÷ 178 179 ÷ 184 185 ÷ 190 191 ÷ 196 197 ÷ 202 203 ÷ 208 209 ÷ 214 215 ÷ 220 221 ÷ 226 227 ÷ 232 233 ÷ 238 239 ÷ 244 245 ÷ 250 251 ÷ 255	000
	19		27	<b>PATTERN SPEED</b> Indexing CW from fast to slow Stop CCW from slow to fast	000 ÷ 127 128 ÷ 190 191 ÷ 192 193 ÷ 255	000
	20		28	<b>PATTERN FADE</b> Lineary from 0% to 100%	000 ÷ 255	000
	21		29	<b>PATTERN TRANSITION</b> Lineary from 0% to 100%	000 ÷ 255	000
	22		30	<b>BACKGROUND INTENSITY</b> Lineary from 0% to 100%	<b>000 ÷ 255</b>	000
	23		31	<b>BACKGROUND STROBE</b> Close Strobe from slow to fast Open Pulse in from slow to fast Open Pulse out from slow to fast Open Random from slow to fast Open	000 ÷ 001 002 ÷ 062 063 ÷ 064 065 ÷ 125 126 ÷ 127 128 ÷ 188 189 ÷ 190 191 ÷ 251 252 ÷ 255	255

Bas	FX	Std	Ext	Function	DMX Value	Default
	24		32	<b>BACKGROUND INTENSITY</b> Lineary from 0% to 100%	000 ÷ 255	000
	25		33	<b>BACKGROUND STROBE</b> Close Strobe from slow to fast Open Pulse in from slow to fast Open Pulse out from slow to fast Open Random from slow to fast Open	000 ÷ 001 002 ÷ 062 063 ÷ 064 065 ÷ 125 126 ÷ 127 128 ÷ 188 189 ÷ 190 191 ÷ 251 252 ÷ 255	255
	26		34	<b>BACKGROUND RED</b> Lineary from 0% to 100%	000 ÷ 255	000
	27		35	<b>BACKGROUND GREEN</b> Lineary from 0% to 100%	000 ÷ 255	000
	28		36	<b>BACKGROUND BLUE</b> Lineary from 0% to 100%	000 ÷ 255	000
	29		37	<b>BACKGROUND WHITE</b> Lineary from 0% to 100%	000 ÷ 255	000
	30		38	<b>RING DIMMER</b> Lineary from 0% to 100%	000 ÷ 255	000
	31		39	<b>RING PATTERN</b> No FX Single Line going around Ring 1 Single Line going around Ring 2 Single Line going around Ring 3 Single Line going around Ring 4 Single Line going around Ring 5 Two Lines going around Ring 1 Two Lines going around Ring 2 Two Lines going around Ring 3 Two Lines going around Ring in opposed direction 1 Two Lines going around Ring in opposed direction 2 Two Lines going around Ring in opposed direction 3 Three Lines going around Ring 1 Three Lines going around Ring 2 Six Lines going around Ring Random Pixels 20 steps 1 Random Pixels 20 steps 2 Random Pixels 20 steps 3 Random Pixels 20 steps 4 Random Pixels 20 steps 5 Ring Opening and closing in horizontal axis Ring Opening and closing in vertical axis Ring Opening and closing in horizontal and vertical axis Ring Opening in horizontal axis and closing in vertical axis Ring divided into 4 parts chase Ring divided into 8 parts chase 2 Lines going from Left to Right Loop 2 Lines going from Top to Bottom Loop Ring divided into 4 parts doing chase Ring divided into 4 parts doing chase Ring divided into 4 parts doing chase Reserved TopBottomLeftRight 2 Lines Swing Random Open of pixels Pixel 1 thru 102 On than 102 thru 1 Off Pixel 1 thru 102 On than 1 thru 102 Off Moving anchor Anchor rotated 180 degree	000 ÷ 016 017 ÷ 022 023 ÷ 028 029 ÷ 034 035 ÷ 040 041 ÷ 046 047 ÷ 052 053 ÷ 058 059 ÷ 064 065 ÷ 070 071 ÷ 076 077 ÷ 082 083 ÷ 088 089 ÷ 094 095 ÷ 100 101 ÷ 106 107 ÷ 112 113 ÷ 118 119 ÷ 124 125 ÷ 130 131 ÷ 136 137 ÷ 142 143 ÷ 148 149 ÷ 154 155 ÷ 160 161 ÷ 166 167 ÷ 172 173 ÷ 178 179 ÷ 184 185 ÷ 190 191 ÷ 196 197 ÷ 214 215 ÷ 220 221 ÷ 226 227 ÷ 232 233 ÷ 238 239 ÷ 244 245 ÷ 250 251 ÷ 255	000
	32		40	<b>RING PATTERN SPEED</b> Indexing CW from fast to slow Stop CCW from slow to fast	000 ÷ 127 128 ÷ 190 191 ÷ 192 193 ÷ 255	000
	33		41	<b>RING PATTERN FADE</b> Lineary from 0% to 100%	000 ÷ 255	000

Bas	FX	Std	Ext	Function	DMX Value	Default
	34		42	<b>RING PATTERN TRANSITION</b> Lineary from 0% to 100%	000 + 255	000
19	35	26	43	<b>RING FOREGROUND INTENSITY</b> Lineary from 0% to 100%	000 + 255	000
20	36	27	44	<b>RING FOREGROUND STROBE</b> Close Strobe from slow to fast Open Pulse in from slow to fast Open Pulse out from slow to fast Open Random from slow to fast Open	000 + 001 002 + 062 063 + 064 065 + 125 126 + 127 128 + 188 189 + 190 191 + 251 252 + 255	255
21	37	28	45	<b>RING FOREGROUND RED</b> Lineary from 0% to 100%	000 + 255	000
22	38	29	46	<b>RING FOREGROUND GREEN</b> Lineary from 0% to 100%	000 + 255	000
23	39	30	47	<b>RING FOREGROUND BLUE</b> Lineary from 0% to 100%	000 + 255	000
	40		48	<b>RING BACKGROUND INTENSITY</b> Lineary from 0% to 100%	000 + 255	000
	41		49	<b>RING BACKGROUND STROBE</b> Close Strobe from slow to fast Open Pulse in from slow to fast Open Pulse out from slow to fast Open Random from slow to fast Open	000 + 001 002 + 062 063 + 064 065 + 125 126 + 127 128 + 188 189 + 190 191 + 251 252 + 255	255
	42		50	<b>RING BACKGROUND RED</b> Lineary from 0% to 100%	000 + 255	000
	43		51	<b>RING BACKGROUND GREEN</b> Lineary from 0% to 100%	000 + 255	000
	44		52	<b>RING BACKGROUND BLUE</b> Lineary from 0% to 100%	000 + 255	000

## 14 - RING LAYOUT

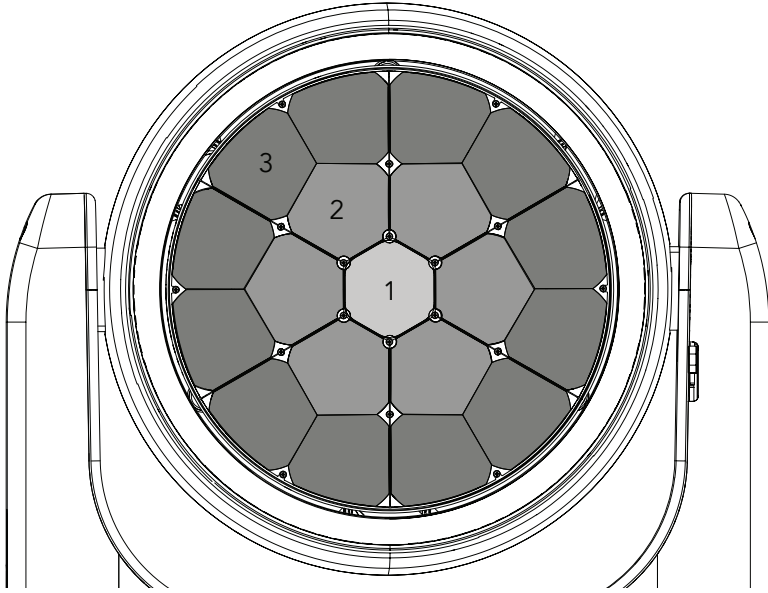

Fig. 09

## 15 - PIXEL LAYOUT

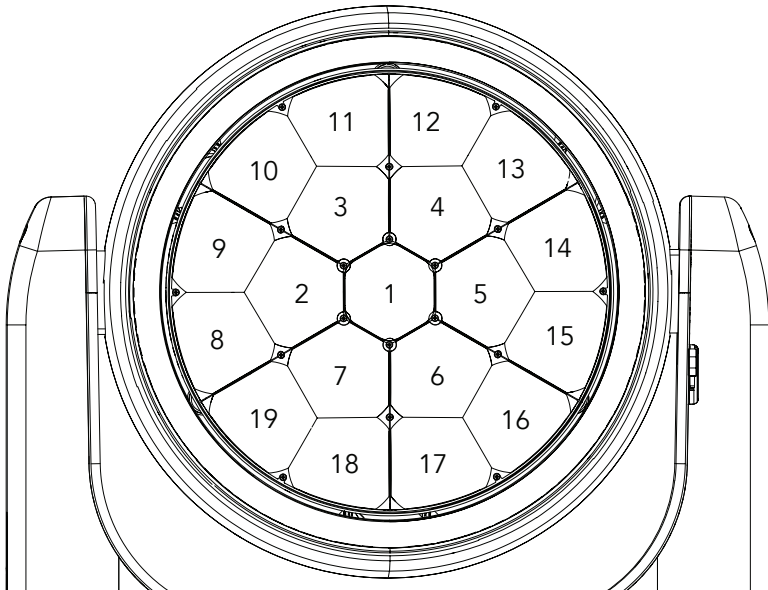

Fig. 10



## 16 - ERROR MESSAGES

The error is shown on the unit display. In the table below, the "ERROR SHOWED ON SCREEN" column lists the possible errors, accompanied by a possible cause ("POSSIBLE" CAUSES "column).

The color of the error messages (listed in the "COLOR MESSAGES" column) is different for each board it refers to ("PCB" column).

On page 32 you can see the location of the various pcb boards.

ERROR SHOWED ON SCREEN	POSSIBLE CAUSES	COLOUR MESSAGES	PCB
[DISPLAY BATTERY ERROR]	Battery not present or not detected from the display PCB.	Green	1U
[BASE FAN 1 ERROR]	Blower for cooling the ignitor failed.	Green	1U
[BASE FAN 2 ERROR]	Blower for cooling the power supply failed.	Green	1U
[DMX ACTIVE]	If transfer configuration is used with dmx signal connected.	Green	1U
[MAINTENANCE TIME]	Need to be done standard maintenance and also reset of elapsed time.	Green	1U
[PAN/TILT PCB ERROR]	Pan tilt pcb not detected.	Blue	2U
[PAN MOTOR ERROR]	This message will appear after the reset of the product if: <ul style="list-style-type: none"> <li>the PAN magnetic-indexing circuit detect a failure (sensor failed or magnet is missing);</li> <li>or the stepping motor is defective;</li> <li>or its driving IC on the PCB is defective;</li> <li>or the product is not located in the default position after the reset of the fixture.</li> </ul>	Blue	2U
[TILT MOTOR ERROR]	This message will appear after the reset of the product if: <ul style="list-style-type: none"> <li>the TILT magnetic-indexing circuit detect a failure (sensor failed or magnet is missing);</li> <li>or the stepping motor is defective;</li> <li>or its driving IC on the PCB is defective;</li> <li>or the product is not located in the default position after the reset of the fixture.</li> </ul>	Blue	2U
[PAN LOCKED]	Pan is locked.	Blue	2U
[TILT LOCKED]	Tilt is locked.	Blue	2U
[PAN SENSOR ERROR]	Pan sensor not detected.	Blue	2U
[LED FAN 1 ERROR]	One of the blowers for cooling the source failed, the source has been switched OFF.	Blue	2U
[LED FAN 2 ERROR]	One of the blowers for cooling the source failed, the source has been switched OFF.	Blue	2U

[TILT SENSOR ERROR]	Tilt sensor not detected.	Blu	2U
[PAN ENCODER ERROR]	Pan encoder not detected.	Blu	2U
[TILT ENCODER ERROR]	Tilt encoder not detected.	Blu	2U
[DRIVER/LED PCB ERROR]	Led driver pcb not detecteld	Yellow	3U
[ZOOM ERROR]	Failure detected during the reset of the ZOOM system, if the zoom lens is not located in its default position.	Yellow	3U
[LED DRIVER TEMPERATURE ERROR]	This error message indicates that an overheating in the head has occurred and the lamp has been switched OFF by the product protection system.	Yellow	3U
[RING DRIVER PCB ERROR]	RING DRIVER PCB not detected during reset	Yellow	3U
[LED PCB ERROR]	LED PCB 1 not detected during reset	Yellow	3U

## IDENTIFICATION OF ELECTRONIC BOARDS

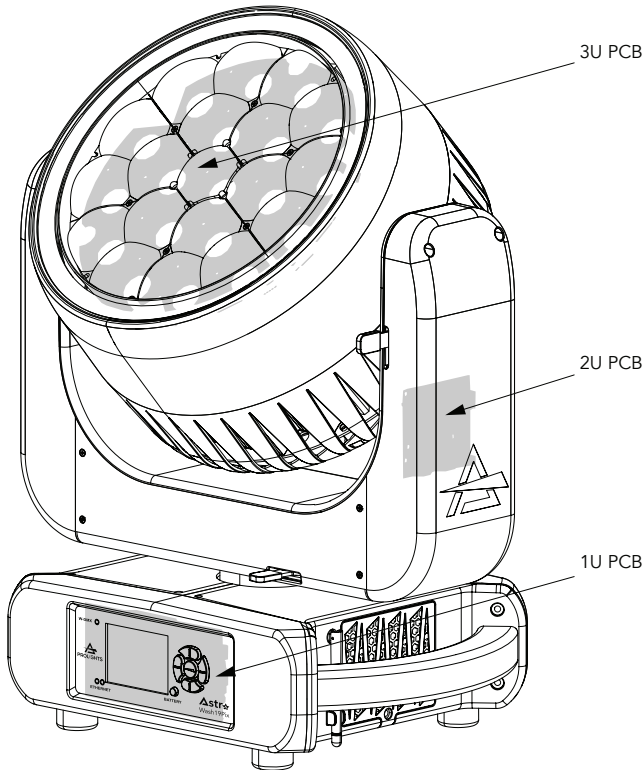
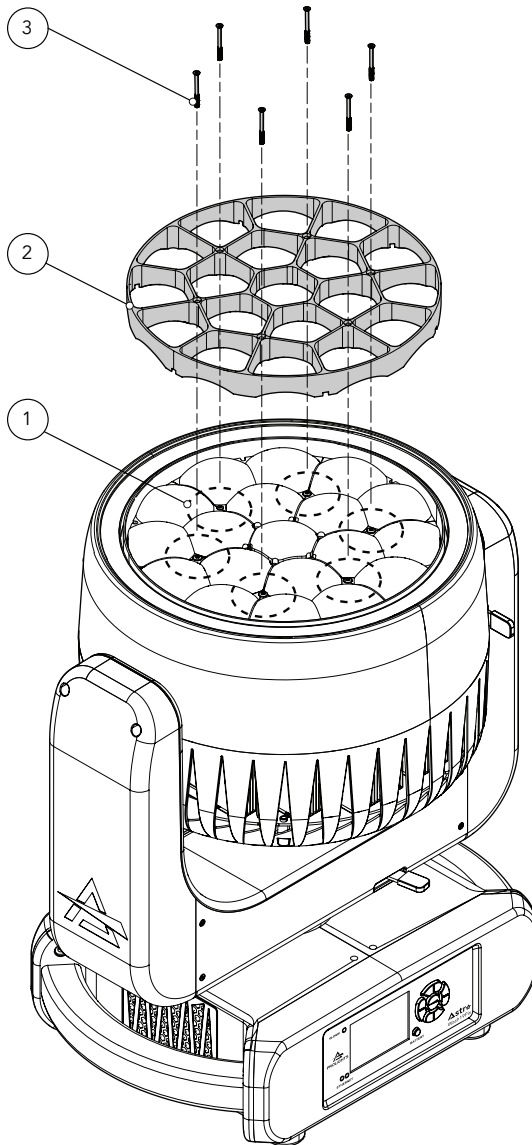

Fig. 11

# 17 - ACCESSORIES INSTALLATION

## EGG CRATE (ASTRAW19PEC - OPTIONAL)



Before removing rear cover, place the head in a horizontal position and engage both the PAN and TILT locks for added stability. See the "PAN AND TILT LOCK" paragrap. Loosen and remove the marked six screws (1). Then insert the egg crate (2) and fix the six screws (3).

Fig. 12

## 18 - PERIODICAL CLEANING

WARNING! Turn OFF power and allow approximately 20 minutes for the fixture to cool down.

---

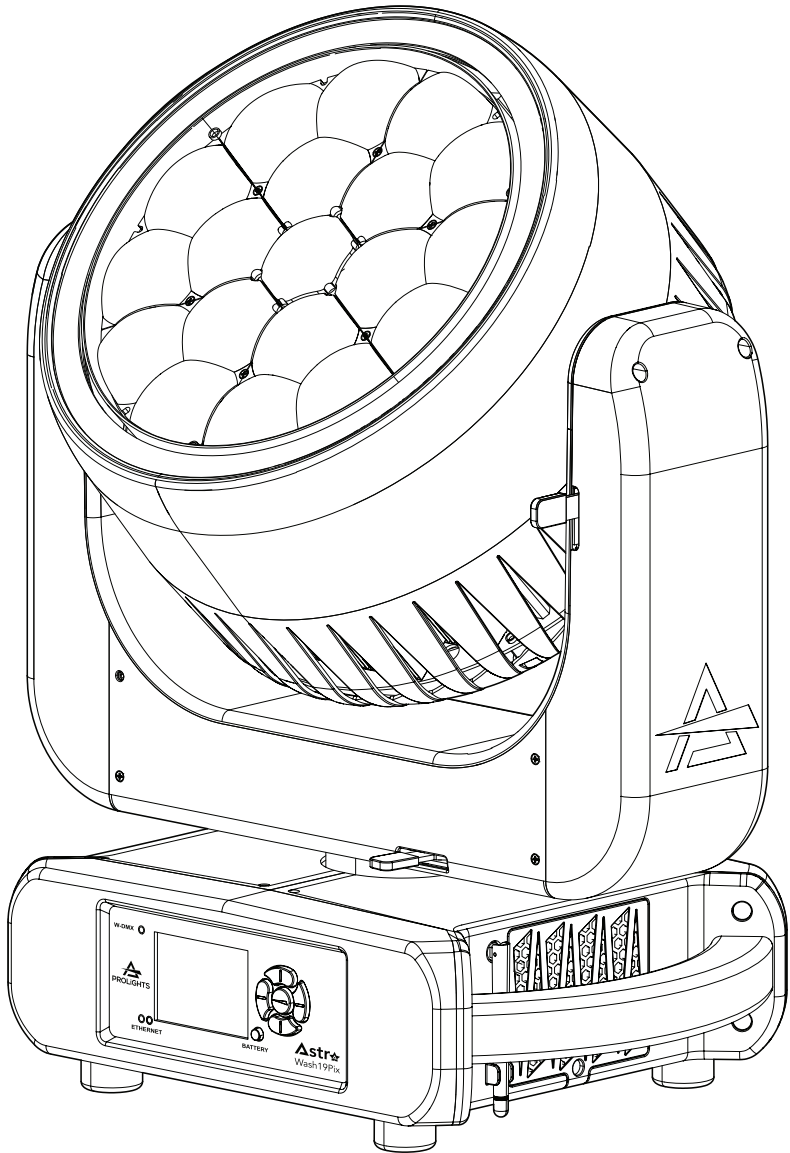

Use a soft cloth dampened with any detergent liquid for cleaning to remove the dirt from the optics.

Fig. 13

# 19 - MAINTENANCE

## MAINTENANCE AND CLEANING THE PRODUCT

**WARNING:** Disconnect from the mains before starting any maintenance work

It is recommended to clean the front at regular intervals, from impurities caused by dust, smoke, or other particles to ensure that the light is radiated at maximum brightness.

- For cleaning, disconnect the main plug from the socket. Use a soft, clean cloth moistened with a mild detergent. Then carefully wipe the part dry. For cleaning other housing parts use only a soft, clean cloth. Never use a liquid, it might penetrate the unit and cause damage to it.
- The user must clean the product periodically to maintain optimum performance and cooling. The user may also upload firmware (product software) to the fixture via the DMX signal input port or USB port using firmware and instructions from PROLIGHTS.
- The frequency of such maintenance operations is to be performed according to various factors, such as the amount of the use and the condition of the installation environment (air humidity, presence of dust, salinity, etc.). It is recommended that the product is subject to annual service by a qualified technician for special maintenance involving at least the following procedures:
  - General cleaning of internal parts.
  - For all the parts subject to friction, using lubricants specifically supplied by PROLIGHTS.
  - General visual check of the internal components, cabling, mechanical parts, etc.
  - Electrical, photometric and functional checks; eventual repairs.
  - Cleaning the lenses. Only use neutral soap and water to clean the lenses, then dry it carefully with a soft, non-abrasive cloth.

**WARNING:** the use of alcohol or any other detergent could damage the lenses.

- All other service operations on the product must be carried out by PROLIGHTS, its approved service agents or trained and qualified personnel.
- It is PROLIGHTS policy to apply the strictest possible calibration procedures and use the best quality materials available to ensure optimum performance and the longest possible component lifetimes. However, optical components are subject to wear and tear over the life of the product, resulting in gradual changes in colours over many thousands of hours of use. The extent of wear and tear depends heavily on operating conditions and environment, so it is impossible to specify precisely whether and to what extent performance will be affected. However, you may eventually need to replace optical components if their characteristics are affected by wear and tear after an extended period of use and if you require fixtures to perform within very precise optical and colour parameters.
- Do not apply filters, lenses or other materials on lenses or other optical components. Use only accessories approved by PROLIGHTS.

## REPLACING THE FUSE

**WARNING:** Before replacing the fuse, unplug the product from the mains.

- Remove the old fuse from the housing with a suitable screwdriver (anticlockwise) and replace it with one of the same type and of the same classification (T8A 250V).

## VISUAL CHECK OF PRODUCT HOUSING

- The parts of the product cover/housing should be checked for eventual damages and breaking start at least every two months. In addition, especially the parts of the front lens holder have to be checked mechanically (by means of movement by the part) if it is firmly fastened to the fixture. If hint of a crack is found on some plastic part, do not use the product until the damaged part will be replaced.
- Cracks or another damages of the cover/housing parts can be caused by the product transportation or manipulation and also ageing process may influence materials.
- This checking is necessary for both fixed installations and preparing product for renting. Any free moving parts inside of the product, cracked cover/housing or any part of front lens not sitting properly in place need to be immediately replaced.

## TROUBLESHOOTING

Problems	Possible causes	Checks and remedies
Product doesn't power ON	<ul style="list-style-type: none"> <li>No power to the product</li> </ul>	<ul style="list-style-type: none"> <li>Check that power is switched ON and cables are plugged in.</li> </ul>
	<ul style="list-style-type: none"> <li>Fuse blown or internal fault</li> </ul>	<ul style="list-style-type: none"> <li>Check if the Fuse is intact and eventually replace it if necessary.</li> <li>Contact the PROLIGHTS Service or authorized service partner. Do not remove parts and/or covers, or carry out any repairs or service that are not described in this Safety and User Manual unless you have both authorization from PROLIGHTS and the service documentation.</li> </ul>
Product reset correctly but does not respond correctly to the controller.	<ul style="list-style-type: none"> <li>Bad signal connection</li> </ul>	<ul style="list-style-type: none"> <li>Inspect connections and cables. Fix eventual bad connections. Repair or replace damaged cables.</li> </ul>
	<ul style="list-style-type: none"> <li>Signal connection not terminated</li> </ul>	<ul style="list-style-type: none"> <li>Insert DMX termination plug in signal output socket of the last product on the signal line.</li> </ul>
	<ul style="list-style-type: none"> <li>Incorrect addressing of the product</li> </ul>	<ul style="list-style-type: none"> <li>Check the product address and control settings</li> </ul>
	<ul style="list-style-type: none"> <li>One of the product is defective and is corrupting the signal transmission on the signal line</li> </ul>	<ul style="list-style-type: none"> <li>Unplug the XLR in and out connectors and connect them directly together to bypass one product at a time until normal operation is regained. Once found the error, have that fixture serviced by a qualified technician.</li> </ul>
Timeout error after fixture reset.	<ul style="list-style-type: none"> <li>One or more hardware components requires mechanical adjustments</li> </ul>	<ul style="list-style-type: none"> <li>Check product stored error messages for more information. Contact PROLIGHTS Service or an authorized service partner.</li> </ul>
Mechanical effect loses position	<ul style="list-style-type: none"> <li>Mechanical hardware require cleaning, adjustment or lubrication</li> </ul>	<ul style="list-style-type: none"> <li>Check product stored error messages for more information. Contact PROLIGHTS Service or an authorized service partner.</li> </ul>
Light output turn OFF Intermittently	<ul style="list-style-type: none"> <li>Fixture is too hot</li> </ul>	<ul style="list-style-type: none"> <li>Check product stored error messages.</li> <li>Allow product to cool.</li> <li>Clean the product and airflow filters.</li> <li>Reduce ambient temperature.</li> </ul>
	<ul style="list-style-type: none"> <li>Hardware failure (temperature sensor, fans, Light source...)</li> </ul>	<ul style="list-style-type: none"> <li>Check product stored error messages for more information. Contact PROLIGHTS Service or an authorized service partner.</li> </ul>
General low light intensity	<ul style="list-style-type: none"> <li>Dirty lens assembly</li> </ul>	<ul style="list-style-type: none"> <li>Clean the fixture regularly.</li> </ul>
	<ul style="list-style-type: none"> <li>Dirty or damaged filters</li> </ul>	<ul style="list-style-type: none"> <li>Install lens assembly properly.</li> </ul>

Contact an authorized service center in case of technical problems or not reported in the table can not be resolved by the procedure given in the table.















**PROLIGHTS** is a trademark of  
**MUSIC & LIGHTS S.r.l.**  
**musiclights.it**

Via A.Olivetti snc  
04026 - Minturno (LT) ITALY  
Tel: +39 0771 72190

**prolights.it**  
support@prolights.it